

---

## ICAF SYSTEM INSTALLATION & OPERATION MANUAL

# ICAF SYSTEM WITH ELECTRIC FAILSAFE RELEASE

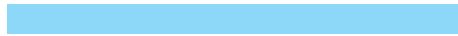

---

### Address

**SIRON Compressed Air Foam**  
Holterhofweg 280A  
NL-7534PT Enschede  
The Netherlands

### Contact

Phone: +31 53 750 30 44  
Email: [info@compressedairfoam.eu](mailto:info@compressedairfoam.eu)  
Website: [www.compressedairfoam.eu](http://www.compressedairfoam.eu)

### Document no's

Revision: -

---

## Table of contents

### ICAF COMPRESSED AIR FOAM SYSTEM WITH ELECTRIC FAILSAFE RELEASE AND FIREFLEX ARC-1 CONTROL PANEL

<u>Description</u>	<u>Form N°</u>
<b>General Section</b> .....	FM-0723-0-07
1. Applicable standards	
2. Listings & Approvals	
3. Environment	
4. General description	
5. Features	
Configuration Description	
Release systems	
Installation	
Preliminary inspection before placing the system in service	
Placing the system in service	
Mechanical trim section	
1. System operation	
Emergency Shut-off instructions	
Post discharge instructions	
Placing back the system in service after operation	
Inspection, tests and maintenance	
<b>Controls Section</b> .....	FM-0723-0-17
User Interface	
1. System status lamps	
2. Keyboard – System main control keys	
3. Keyboard – Menu navigation keys	
4. Keyboard – User defined keys	
5. Local alphanumeric display	
System sequence of operation	
System wiring details	
<b>ICAF System Trim Schematic</b> .....	FM-0723-0-10
1. Description	
2. Normal condition	
Trim schematic	
Trim components	

Continued on next page...



## Table of contents (cont'd)

<b>Air Supply Section</b> .....	FM-0723-0-12
1. Design & selection	
2. Interconnection piping to ICAF system	
3. Operation	
4. Recharge cylinders	
5. Maintenance and Inspection	
<b>Foam Supply Section</b> .....	FM-0723-0-13
1. Foam storage tank	
2. Foam concentrate	
3. Foam tank design and selection	
4. Interconnection piping to ICAF system	
5. Operation	
6. Filling procedure	
7. Maintenance and Inspection	
<b>System Characteristics Section</b> .....	FM-0723-0-14
Mounting & installation details	
Dimensional data	
<b>User Notes</b> .....	FM-0723-0-16
<b>Limited Warranty</b>	



# ICAF - Integrated Compressed Air Foam System

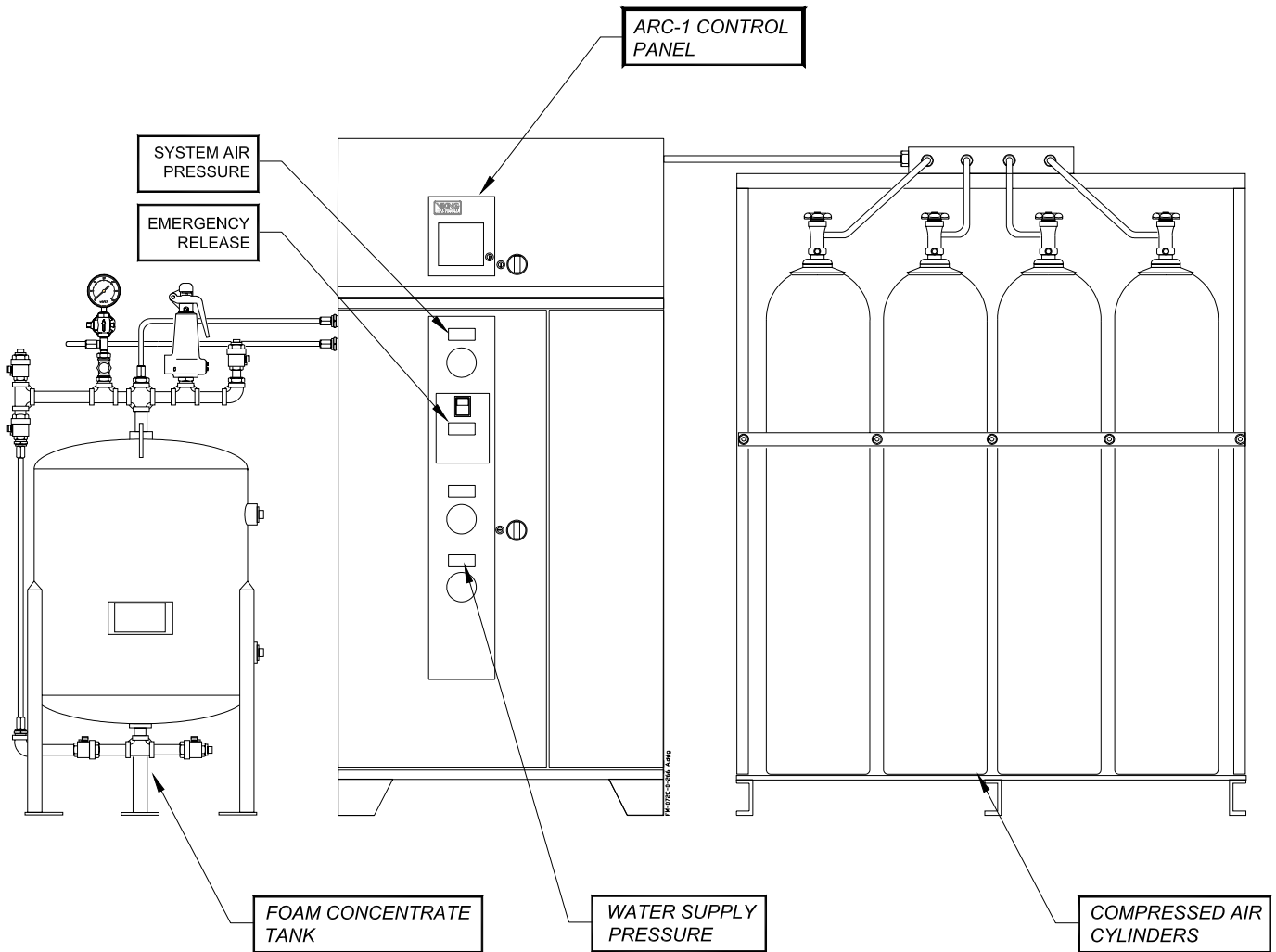

## Table of contents

### ICAF COMPRESSED AIR FOAM SYSTEM WITH ELECTRIC FAILSAFE RELEASE AND FIREFLEX ARC-1 CONTROL PANEL

<u>Description</u>	<u>Form N°</u>
<b>General Section</b> .....	FM-0723-0-07
1. Applicable standards	
2. Listings & Approvals	
3. Environment	
4. General description	
5. Features	
Configuration Description	
Release systems	
Installation	
Preliminary inspection before placing the system in service	
Placing the system in service	
Mechanical trim section	
1. System operation	
Emergency Shut-off instructions	
Post discharge instructions	
Placing back the system in service after operation	
Inspection, tests and maintenance	
<b>Controls Section</b> .....	FM-0723-0-17
User Interface	
1. System status lamps	
2. Keyboard – System main control keys	
3. Keyboard – Menu navigation keys	
4. Keyboard – User defined keys	
5. Local alphanumeric display	
System sequence of operation	
System wiring details	
<b>ICAF System Trim Schematic</b> .....	FM-0723-0-10
1. Description	
2. Normal condition	
Trim schematic	
Trim components	

Continued on next page...



## Table of contents (cont'd)

<b>Air Supply Section</b> .....	FM-0723-0-12
1. Design & selection	
2. Interconnection piping to ICAF system	
3. Operation	
4. Recharge cylinders	
5. Maintenance and Inspection	
<b>Foam Supply Section</b> .....	FM-0723-0-13
1. Foam storage tank	
2. Foam concentrate	
3. Foam tank design and selection	
4. Interconnection piping to ICAF system	
5. Operation	
6. Filling procedure	
7. Maintenance and Inspection	
<b>System Characteristics Section</b> .....	FM-0723-0-14
Mounting & installation details	
Dimensional data	
<b>User Notes</b> .....	FM-0723-0-16
<b>Limited Warranty</b>	



## General Section

### Foam Supply

Foam concentrate is stored inside a stainless steel pressure vessel type tank as described in the Foam Supply Section.

There are two interconnection lines provided on all foam storage tanks. One connection is used to pressurize the foam storage tank with compressed air (*circled item 3*) on alarm condition, the other to provide foam concentrate to the mixing chamber (*circled item 2*). Piping between the foam storage tank and the ICAF System is factory prepared according to the installation arrangement and is supplied with the system.

### System Supervision

The ARC-1 release control panel supervises the air and water supplies to insure system's reliability at all times.

A high pressure transducer (*C7*) is provided to supervise cylinder bank pressure. The intent of this device is to provide a supervisory signal if the cylinder bank pressure goes under the minimum pressure required to provide air supply for the specified discharge time. A cylinder bank pressure under 2200 psi (15,158 kPa) will cause the controller to go in a supervisory alarm mode.

An alarm pressure switch (*B15*) is provided with an alarm test valve (*B5*) and a drain valve (*B6*). The alarm pressure switch is operated through the system's water alarm line when the system is discharged. System actuation, manual or automatic, will cause the control panel to go under alarm and flow confirmation modes.

The main control valve (*B10*) is supervised from abnormal position by an integrated supervisory switch. The supervisory switch supervises the valve in an open position and will cause the controller to go in a supervisory alarm mode in case the main control valve is not in a completely open position.

### Release Systems

The system can be activated manually, electrically using solenoid valves or pneumatically using a pilot line. When electrically activated, the solenoid valves are controlled by FireFlex's ARC-1 release controller listed for releasing and compatible with the solenoid valves.

#### Electric Fail Safe Release:

Electrically controlled ICAF Systems require an electric Solenoid Valve (*R2*) controlled by the Approved ARC-1 Control Panel with compatible detection devices (if provided with this system, see Controls Section for details). The Failsafe mode maintains the system activated in case of total power failure (AC and DC) of the release control panel. An emergency release valve (*R1*) is provided for manual override in case of a malfunction of the release control panel.

In fire condition, when the detection condition is satisfied the ARC-1 Control Panel energizes the Solenoid Valve (*R2*) open, the pneumatic control line is then pressurized causing the water, air and foam pneumatically activated control valves (*A1, B9 & F1*) to open simultaneously and generate the CAF through a piping system into the discharge devices and to be

discharged over the area served by the discharge devices.

#### Electric Release:

Electrically controlled ICAF Systems require an electric Solenoid Valve (*R2*) controlled by the Approved ARC-1 Control Panel with compatible detection devices (if provided with this system - see Controls Section for details). An emergency release valve (*R1*) is provided for manual override in case of a malfunction of the release control panel.

In fire condition, when the detection condition is satisfied the ARC-1 Control Panel energizes the Solenoid Valve (*R2*) open, the pneumatic control line is then pressurized causing the water, air and foam pneumatically activated control valves (*A1, B9 & F1*) to open simultaneously and generate the CAF through a piping system into the discharge devices and to discharge over the area served by the discharge devices.

#### Pneumatic Release:

Pneumatically controlled ICAF Systems require a pneumatic release system, equipped with fixed temperature releases, and/or pilot heads. An emergency release valve (*R1*) is provided for manual override in case of a malfunction of the release line.

Release trim, for pneumatically controlled ICAF Systems utilizes a Pneumatic Actuator (*R5*) normally held closed by pressure maintained in the pneumatic release system.

The air supply for the pneumatic release piping system is provided by the cylinders bank installed as part of the ICAF System unit. It is recommended to provide Inspectors Test Connections on the release system.

In fire condition, the low pressure resulting in the operation of the pneumatic release system causes the Pneumatic Actuator (*R5*) to open, the pneumatic control line is then pressurized causing the water, air and foam pneumatically operated control valves (*A1, B9 & F1*) to open simultaneously and generate the CAF through a piping system into the discharge devices and to discharge over the area served by the discharge devices.

#### Manual Release.

Manually actuated ICAF Systems provide a manual means for the user to actuate the system. Manual actuation is accomplished by turning the manual release valve (*R1*) in the open position (identified "Emergency Release" on the front of the unit).

In fire condition, by turning the "Emergency Release" valve in the open position the user will cause the pneumatic control line to pressurize, causing the water, air and foam pneumatically operated control valves (*A1, B9 & F1*) to open simultaneously and generate the CAF through a piping system into the discharge devices and to discharge over the area served by the discharge devices.



## General Section

### Installation

ICAF Systems shall be located, installed, or suitably protected so as to not be subjected to mechanical, chemical, or other damage that could render them inoperative. Foam concentrates are subject to freezing or deterioration from prolonged storage at high temperatures, the system shall therefore be located in a room with ambient temperature between 40°F to 110°F (4°C to 43°C).

Although it is preferable to locate the system outside the protected area, in the case where there is no other alternative, provisions should be made to ensure that the system is not going to be exposed to fire or mechanical damage in a manner that would affect its operation.

Systems shall also be installed so that inspection, testing, recharging, and other maintenance are facilitated and interruption to protection is held to a minimum.

1. Install the ICAF System unit, cylinders bank and foam concentrate tank according to the technical data supplied.

**Note:** The drain collector shall be connected to an open drain. Do not restrict or reduce drain piping.

2. Install the open nozzles piping network in accordance with the ICAF System's Design Manual (FM-090M-0-01).
3. Install the releasing piping (if applicable), detection and signaling circuits in accordance with applicable NFPA standards.
4. Conform to local municipal or other codes regarding installations of fire protection systems.
5. Perform preliminary inspection outlined below prior to putting system in service.
6. Put the system into operation as outlined below.
7. Perform the annual inspection sequence and test each detector and alarm unit.
8. If the system does not operate as it should, make the necessary corrections according to manuals issued or consult your distributor or FireFlex Systems Inc.
9. Make sure that the building owner or a delegated representative has received instructions regarding the operation of the system.

### Preliminary inspection before placing the system in service

(Refer to TRIM SCHEMATIC section)

1. Open door to mechanical section. Main Water Supply Control Valve (B10) should be CLOSED. Priming valve (B1) must be CLOSED. Air supply must be CLOSED (see AIR SUPPLY SECTION). Flow Test Valve (B6) and main drain valve (B16) must be CLOSED. Alarm test valve (B5) must be CLOSED. Emergency Release valve (R1) is CLOSED. System flushing valve (A3) and foam injector flushing valve (F5) must be CLOSED. All gauges (B11, B12, B17 and F4) should show 0 psi pressure.

2. Connect all detection and alarm audible devices (provided by others) according to electrical schematics (see field wiring diagrams in SYSTEM WIRING section).
3. Connect the AC power for the control panel on a separate circuit breaker in the electric distribution panel (see TBA field wiring diagram in SYSTEM WIRING section).

**Note:** Do not use these circuit breakers for other parallel applications. If necessary, equip each circuit breaker with a security seal in order to avoid accidental closing.

4. After the system is set, operation of the system will require the pressurization of the actuation line to open the pneumatically operated control valves. This may be by automatic or manual operation of one of the release systems described above. For specific trim arrangement, refer to TRIM SCHEMATIC section.

**Note:** Electric Release: Solenoid valves, system control panels and electrical detectors must be compatible. Consult ARC-1 Installation & Operation Manual FM-072Z-0-01 for devices compatibility charts.

### Placing the system in service:

(Refer to TRIM SCHEMATIC section)

1. Verify the following:
  - a) The system Main Water Supply Control Valve (B10) is CLOSED.
  - b) The system has been properly drained.
  - c) Flow Test Valve (B6) is OPEN.
  - d) The Emergency Release Valve (R1) is CLOSED.
  - e) The system water supply piping is pressurized up to the CLOSED Main Water Supply Valve (B10) and the priming line is pressurized up to the CLOSED Priming Valve (B1).
  - f) The system flushing valve(s) (A3) is(are) CLOSED.
  - g) The foam injector flushing valve (F5) is CLOSED.
2. Verify that all releasing devices are set and that auxiliary drain valves are CLOSED.
  - a) OPEN Priming Valve (B1).
3. OPEN Main Drain Valve(s) (B16).
4. PARTIALLY OPEN Main Water Supply Control Valve (B10).
5. When full flow develops from the Flow Test Valve (B6), CLOSE the Flow Test Valve.
  - a) Verify that there is no flow from the open Main Drain Valve (B16).
6. CLOSE Main Drain Valve(s) (B16).
7. FULLY OPEN and secure the Main Water Supply Control Valve (B10).
8. Verify that the Alarm Test Valve (B5) is CLOSED and that all other valves are in their "normal" operating position.





## General Section

9. Depress the plunger of the Drip Check Valve (B7). No water should flow from the Drip Check when the plunger is pushed.
10. Open air supply, (Refer to AIR SUPPLY section for details).
11. Place the foam supply in SET condition, (Refer to FOAM SUPPLY section for details).
12. Check and repair any leaks.
13. On new installations, systems that have been placed out of service, or where new equipment has been installed, trip test system to verify that all equipment functions properly. Refer to INSPECTION & MAINTENANCE – ANNUALLY section for instructions.

**CAUTION !** Performing a trip test results in operation of the ICAF System. CAF will flow into the distribution piping. Take necessary precautions to prevent any damage.

14. After completing the trip test, perform instructions in INSPECTION & MAINTENANCE – SEMI-ANNUALLY section.

**Note:** When a valve has been removed from service and is subject to freezing or will be out of service for an extended period of time, all water piping must be removed from the priming chamber, trim piping, water supply piping and any other trapped areas.

15. Notify the Authority Having Jurisdiction, remote station alarm monitors, and those in the affected area that the system is in service.

### **Mechanical trim section**

(Refer to TRIM SCHEMATIC section)

#### **1. System Operation**

##### **In the SET condition:**

System water supply pressure enters the priming chamber of the Flow Control Valve (B14) through the priming line which includes a normally open priming valve (B1), strainer (B2), restricted orifice (B3) and spring loaded check valve (B4).

System air supply pressurizes the normally closed air pneumatically operated control valve (A1), and the pneumatic control lines.

- Electric Fail Safe Release: In the SET condition, water supply pressure is trapped in the priming chamber by a spring loaded check valve (B4) and the normally closed Water pneumatically actuated control valve (B9). The pressure in the priming chamber holds the Flow Control Valve (B14) clapper closed, keeping the outlet chamber and system piping dry.

System air supply pressurizes the normally closed air pneumatically actuated control valve (A1) and the normally closed Solenoid Valve (R2) prevents the air to fill up the pneumatic control lines, keeping the system closed. The control line vent Solenoid Valve is closed (R4).

- Electric Release: In the SET condition, water supply pressure is trapped in the priming chamber by a spring loaded check valve (B4) and the normally closed water pneumatically actuated control valve (B9). The pressure in the priming chamber holds the Flow Control Valve (B14) clapper closed, keeping the outlet chamber and system piping dry.

System air supply pressurizes the normally closed air pneumatically actuated control valve (A1) and the normally closed Solenoid Valve (R2) prevents the air to fill up the pneumatic control lines, keeping the system closed.

- Pneumatic Release: In the SET condition, water supply pressure is trapped in the priming chamber by a spring loaded check valve (B4) and the normally closed water pneumatically actuated control valve (B9). The pressure in the priming chamber holds the Flow Control Valve (B14) clapper closed, keeping the outlet chamber and system piping dry.

System air supply pressurizes the normally closed air pneumatically actuated control valve (A1) and the pneumatic release system. The Pneumatic Actuator (R5) is held closed by pressure maintained in the pneumatic release system, preventing the air to fill up the pneumatic control lines, keeping the system closed.

- Manual Release: In the SET condition, water supply pressure is trapped in the priming chamber by a spring loaded check valve (B4) and the normally closed water pneumatically actuated control valve (B9). The pressure in the priming chamber holds the Flow Control Valve (B14) clapper closed, keeping the outlet chamber and system piping dry.

System air supply pressurizes the normally closed air pneumatically actuated control valve (A1). The normally closed Emergency Release Valve (R1) prevents the air to fill up the pneumatic control lines, keeping the system closed.

##### **In a FIRE condition:**

- Electric Fail Safe Release: When the detection system operates, system Control Panel activates an alarm and energizes normally closed Solenoid valve (R2) to open.
- Electric Release System: When the detection system operates, system Control Panel activates an alarm and energizes normally closed three way Solenoid valve (R2) to open.
- Pneumatic Release System: When a releasing device operates, pressure in the pneumatic release system escapes, causing the Pneumatic Actuator (R5) to open.
- Manual Release: When the Emergency Release Valve (R1) is opened, the pressure control line is pressurized and the pneumatically actuated control valves for water (B9), air (A1) and foam (F1) are all opened simultaneously.



## General Section

Pressure is released from the priming chamber to the open drain manifold faster than it is supplied through the restricted orifice (B3). The Flow Control Valve (B14) clapper opens to allow water to flow into the system piping and alarm devices, causing the water flow alarm connected to the Alarm Pressure Switch (B15) to activate. The foam pneumatically actuated control valve (F1) opens, pressurizing the foam concentrate tank with air and expelling the foam concentrate in the foam injection line through the dip tube. Water, air and foam concentrate being supplied at the mixing chamber, Compressed Air Foam (CAF) is then generated and moves inside the piping network toward the distribution nozzles.

### When the discharge time has elapsed:

- Electric Fail Safe Release: The Control Panel de-energizes the normally closed Solenoid valve (R2), allowing it to close, the normally closed solenoid (R4) is energized allowing the pressure control line to vent and close the pneumatically actuated control valves for water (B9), air (A1) and foam (F1). The Flow Control Valve (B14) re-primed and closes, stopping the flow of water through the piping system.
- Electric Release System: The Control Panel de-energizes the normally closed three way Solenoid valve (R2), allowing it to close. The pressure control line is then vented allowing the pneumatically actuated control valves for water (B9), air (A1) and foam (F1) to close. The Flow Control Valve (B14) re-primed and closes, stopping the flow of water through the piping system

### Emergency Shut-off instructions

(Refer to TRIM SCHEMATIC section)

1. Press and hold the F3 function key labelled: "System Shut-Off" on the keypad of the ARC-1 panel until its adjacent red lamp is turned ON.
2. Close the system main water supply control valve (B10) inside the ICAF cabinet. The red lamp labelled "Discharge suspended" will turn ON.

**Note:** This special function is not intended to be used prior to the CAF discharge.

### Post Discharge Instructions

(Refer to TRIM SCHEMATIC section)

#### To take the system Out of Service:

**Warning !** Placing the control valves or detection system out of service may eliminate the fire protection capabilities of the system. Prior to proceeding, notify all Authorities Having Jurisdiction. Consideration should be given to employ a fire patrol in the affected areas.

ICAF Systems that have been exposed to a fire must be returned to service as soon as possible. The entire system must be inspected for damage, and repaired or replaced as necessary.

1. Close Water Supply Control Valve (B10).
2. Open system Main Drain Valve(s) (B16).
3. Open the System Flushing Valve (A3) to flush the piping network.
4. Open the Foam Injectors Flushing Valve (F5) to flush the foam injectors.
5. Silence alarms (if provided; refer to CONTROL PANEL section for additional details).

**Note:** Electric alarms controlled by a pressure switch installed in the ½" (15mm) NPT connection for a Non-interruptible Alarm Pressure Switch cannot be shut-off until the Flow Control Valve (B14) is reset or taken out of service.

6. For Pneumatic Release Systems, shut-off the air supply (refer to TRIM SCHEMATIC section).
7. Close Priming Valve (B1) (optional).
8. Close Air Supply (Refer to AIR SUPPLY for details).
9. Replace any detectors, pilot heads or other release device that have operated.
10. Replace any nozzle that have been damaged or exposed to fire conditions. Obstructed nozzles may be cleaned and re-installed.
11. Perform all maintenance procedures recommended in MAINTENANCE, describing individual components of the system that has operated.

### Placing the system back in service after operation

(Refer to TRIM SCHEMATIC section)

**IMPORTANT:** After a fire, make sure it is completely extinguished. If necessary, place a fire patrol in the zone covered by the system. ICAF Systems that have been subjected to fire must be returned to service as soon as possible. The entire system must be inspected for damage, and repaired or replaced as necessary.

1. Verify that the system has been properly drained. Main Water Supply Control Valve (B10) and priming valve (B1) must be CLOSED. Flow Test Valve (B6) and main drain valves (B16) should be OPEN.
2. Open the System Flushing Valve(s) (A3) to flush the piping network.
3. Open the Foam Injectors Flushing Valve (F5) to flush the foam injectors.
4. Air supply must be CLOSED (see AIR SUPPLY SECTION). Verify that the Emergency Release valve (R1) is CLOSED. System flushing valve (A3) and foam injector flushing valve (F5) must both be CLOSED. All gauges (B11, B12, B17 and F4) should show 0 psi pressure.
5. Refill the foam concentrate tank (T1) according to the procedure described in the FOAM SUPPLY section.



## General Section

6. Refill the compressed air cylinders bank (C2) according to the procedure described in the AIR SUPPLY section.

**NOTICE:** Empty cylinders must be recharged by FireFlex or its trained authorized agent. Contact FireFlex After Sales Support Department for information about the nearest authorized agent to your location.

7. Reset the System Control Panel (refer to CONTROL PANEL section).
8. Open priming valve (B1).
9. Open Flow Test Valve (B6).
10. Partially open Main Water Supply Valve (B10), when full flow develops from Flow Test Valve (B6), close the Flow Test Valve. Verify that there is no flow from the System Main Drain Valves (B16).
11. Close the System Main Drain Valve(s) (B16).
12. Fully open and secure the Main Water Supply Control Valve (B10).
13. Verify that the Alarm Test Valve (B5) and all other valves are at their NORMAL operating position.
14. Depress the plunger of Drip Check (B7). No water should flow from the Drip Check when the plunger is pushed.
15. Open air supply (refer to AIR SUPPLY section for details).
16. Place the foam supply in NORMAL condition (refer to FOAM SUPPLY for details).
17. Reset the System Control Panel.
18. Notify the Authority Having Jurisdiction, remote station alarm monitors, and those in the affected area that the system is in service.



### Inspections, test & maintenance

Regular inspections, tests, and maintenance should be performed at intervals specified in this document to verify that the ICAF System is in good operating condition and that it functions as intended. Components shall be restored to full operational condition following inspection and testing.

The frequency of the inspections may vary due to contaminated water supplies, corrosive or humid atmospheres as well as the condition of the air supply to the system. In addition to the instructions herewith, local Authority Having Jurisdiction may have additional maintenance, testing and inspection requirements which must be followed.

**Warning !** Any system maintenance which involves placing a control valve or detection system out of service may eliminate the fire protection capabilities of that system. Prior to proceeding, notify all Authorities Having Jurisdiction. Consideration should be given to the employment of a fire patrol in the affected areas.

### **RESPONSIBILITY of the Owner.**

1. The responsibility for properly maintaining the compressed air foam system shall be that of the owner of the property.
2. Inspection, testing, and maintenance shall be implemented in accordance with procedures meeting or exceeding those established in this document.
3. These tasks shall be performed by FireFlex's authorized personnel who have developed competence through training and experience.
4. It is the responsibility of the owner to promptly correct or repair deficiencies, damaged parts, or impairments found while performing the inspection, test, and maintenance requirements of this document.
5. Corrections and repairs shall be performed by qualified FireFlex's authorized personnel.
6. The building owner shall not make changes in the occupancy, the use or process, or the materials used or stored in the building without evaluation of the fire protection systems for their capability to protect the new occupancy, use, or materials.
7. Where changes are identified, the owner shall promptly take steps to evaluate the adequacy of the installed system in order to protect the building or hazard in question. Where the evaluation reveals a deficiency causing a threat to life or property, the owner shall make appropriate corrections.

### **Records.**

1. Records of inspections, tests, and maintenance of the system and its components shall be maintained by the owner and made available to the Authority Having Jurisdiction upon request.
2. Records shall indicate the procedure performed (e.g., inspection, test, or maintenance), the organization that performed the work, the results, and the date.
3. Original records shall be retained for the life of the system.
4. Test results shall be compared with those of the original acceptance test (if available) and with the most recent test results.



The following requirements are based upon NFPA-25:

### Monthly:

#### INSPECTION:

##### ICAF Discharge Nozzles:

ICAF discharge nozzles shall be inspected visually and maintained to ensure that they are in place, continue to be aimed or pointed in the direction intended in the system design, and are free from external loading and corrosion.

Misaligned discharge nozzles shall be adjusted (aimed) by visual means, and the discharge patterns shall be checked at the next scheduled flow test.

Only ICAF Discharge nozzles are approved and shall be used with ICAF System. Inspection shall verify that unlisted combinations of discharge nozzles have not been substituted.

##### Control Valves:

The valve inspection shall verify that the valves are in the following condition:

1. In the normal open or closed position
2. Properly sealed, locked, or supervised
3. Accessible
4. Provided with appropriate wrenches
5. Free from external leaks

##### Flow Control Valves:

Valve enclosure heating equipment for ICAF Systems subject to freezing shall be inspected during cold weather for its ability to maintain a minimum temperature of at least 4°C (40°F).

The gauge on the supply side of the flow control valve shall indicate that the normal supply water pressure is being maintained.

The gauge monitoring the ICAF system air pressure shall be inspected monthly to verify that it indicates that normal pressure is being maintained.

The flow control valve shall be externally inspected to verify the following:

1. The valve is free from physical damage.
2. All trim valves are in the appropriate open or closed position.
3. The valve seat is not leaking.
4. Electrical components are in service.

### Quarterly:

#### INSPECTION:

##### Drainage:

The area beneath and surrounding a ICAF System shall be inspected to ensure that drainage facilities, such as trap sumps and drainage trenches, are not blocked and retention embankments or dikes are in good repair.

##### System Piping and Fittings:

System piping and fittings shall be inspected for the following:

1. Mechanical damage (e.g., broken piping or cracked fittings)
2. External conditions (e.g., missing or damaged paint or coatings, rust, and corrosion)
3. Misalignment or trapped sections
4. Low point drains (automatic or manual)
5. Location and condition of rubber-gasketed fittings

##### Hangers and Supports:

Hangers and supports shall be inspected for the following and repaired as necessary:

1. Condition (e.g., missing or damaged paint or coating, rust, and corrosion)
2. Secure attachment to structural supports and piping
3. Damaged or missing hangers

#### TEST:

##### Water-Flow Alarm:

All water-flow alarms shall be tested in accordance with the manufacturer's instructions.

### Semiannually:

#### TEST:

##### Supervisory Switches:

A distinctive signal shall indicate movement from the valve's normal position during either the first two revolutions of a hand wheel or when the stem of the valve has moved one-fifth of the distance from its normal position.

The signal shall not be restored at any valve position except the normal position.





### **Annually:**

#### **TEST:**

##### **Control Valve:**

Each control valve shall be operated through its full range and returned to its normal position.

##### **Main Drain:**

A main drain test shall be conducted to determine whether there has been a change in the condition of the water supply piping and control valves.

##### **Operational Test:**

Operational tests shall be conducted to ensure that the ICAF System responds as designed, both automatically and manually.

The test procedures shall simulate anticipated emergency events so the response of the ICAF System can be evaluated.

Protection shall be provided for any devices or equipment subject to damage by system discharge during tests.

Where the nature of the protected property is such that CAF cannot be discharged for test purposes, the trip test shall be conducted in a manner that does not necessitate discharge in the protected area.

Where the nature of the protected property is such that CAF cannot be discharged unless protected equipment is shut down (e.g., energized electrical equipment), a full flow system test shall be conducted at the next scheduled shutdown. In all cases, the test frequency shall not exceed 3 years.

Where discharge from the system discharge devices would create a hazardous condition or conflict with local requirements, an approved alternate method to achieve full flow conditions shall be permitted.

##### **Response Time:**

Under test conditions, the automatic fire detection systems, when exposed to a test source, shall operate within the requirements of NFPA 72, National Fire Alarm Code, for the type of detector provided and the response time shall be recorded.

##### **Discharge Time:**

The time lapse between operation of detection systems and water delivery time to the protected area shall be recorded for open discharge devices.

##### **Discharge Patterns:**

The discharge patterns from all of the nozzles shall be observed to ensure that patterns are not impeded by plugged nozzles and to ensure that nozzles are correctly positioned and that obstructions do not prevent discharge patterns from covering surfaces to be protected.

Where obstructions occur, the piping and nozzles shall be cleaned and the system retested.

##### **Pressure Readings:**

Pressure readings shall be recorded at the main control valve and the CAF outlet.

Readings shall be compared to the design pressures to ensure the original system design requirements are met.

##### **Multiple Systems:**

The maximum number of systems expected to operate in case of fire shall be tested simultaneously to check the adequacy of the water supply.

##### **Manual Operation:**

Manual actuation devices shall be tested.

##### **Return to Service:**

After the full flow test, the system shall be returned to service in accordance with the instructions described in this manual.

Low points in the ICAF System shall be drained after each operation.

Records indicating the date the ICAF System was last tripped and the tripping time as well as the individual and organization conducting the test shall be maintained at a location or in a manner readily available for review by the Authority Having Jurisdiction.

### **MAINTENANCE:**

##### **Strainers:**

Priming line strainer (basket or screen) shall be removed, cleaned and inspected.

### **Every 5 years:**

#### **TEST:**

##### **Gauges:**

Gauges shall be tested every 5 years by comparison with a calibrated gauge. Gauges not accurate to within 3 percent of the full scale shall be recalibrated or replaced.

#### **INSPECTION:**

##### **Flow Control Valve:**

The interior of the flow control valve shall be inspected to verify that all components operate properly. Internal components shall be cleaned, repaired, or replaced as necessary.



### User Interface

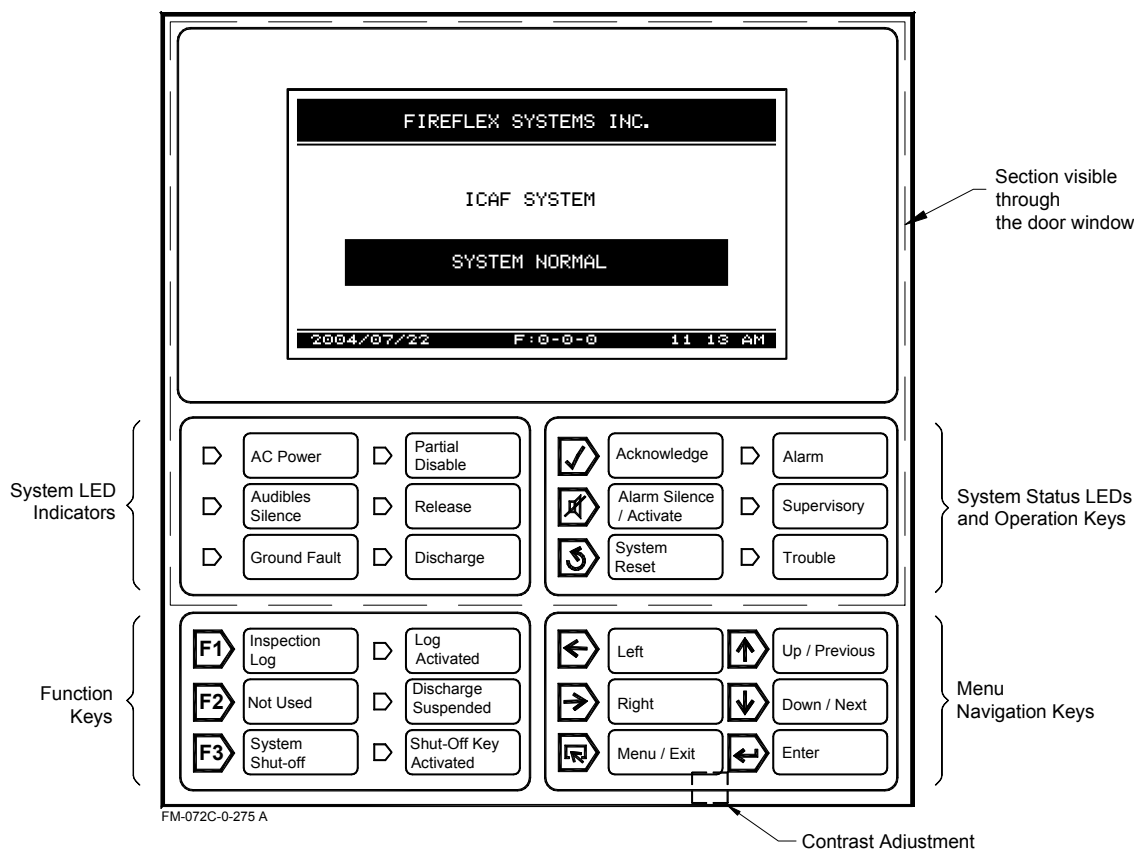

### 1. System Status Lamps

Alarm, Trouble and Supervisory lamps will flash for their respective events until acknowledged, at which point the lamp will illuminate steadily. The local Alphanumeric Display will provide additional details for every event (refer to screen details in the text).

- "AC POWER": A green lamp that illuminates steadily to indicate the presence of AC power and flashes when system is on battery power only.
- "AUDIBLES SILENCE": A yellow lamp that illuminates steadily when the ALARM SILENCE switch has been depressed after an alarm. Lamp will begin flashing upon subsequent alarm.
- "GROUND FAULT": A yellow lamp that illuminates steadily during a ground fault condition.
- "PARTIAL DISABLE": A yellow lamp that illuminates steadily when any input or output circuit is disabled by the user.
- "RELEASE": A red lamp that illuminates steadily when solenoid(s) is (are) activated and release occurs. This lamp will flash when discharge is stopped (cycling type systems only).
- "DISCHARGE": A red lamp that illuminates steadily when the actual water flow has occurred.

- "ALARM": Red lamp that flashes when an alarm occurs and becomes steady after event have been acknowledged.
- "SUPERVISORY": A yellow lamp that flashes upon activation of a supervisory device (such as a tamper switch and air pressure switch or sensor) and becomes steady after event have been acknowledged.
- "TROUBLE": A yellow lamp that flashes for any trouble condition and becomes steady after event have been acknowledged. System internal routines trouble will activate the trouble signals continuously.
- "OPTION LAMPS": The three (3) option lamps (factory-defined and identified Led1, Led2 & Led3) are used for various special functions.

**Contrast Adjustment:** A small potentiometer is provided on the circuit board to adjust the LCD contrast level. This potentiometer (shown above) can be accessed from the bottom of the LCD module when the cabinet door is open and adjusted with a small flat screwdriver.

### 2. Keyboard - System Main Control Keys

Panel is provided with a membrane type keyboard as shown on the previous page. Local sounder will beep once every time a valid control key is depressed. Sounder will beep twice anytime an invalid entry is made or user is scrolling too fast with the navigation keys. Various system main control keys are described below:

**ACKNOWLEDGE:** Every new event must be acknowledged. Depressing this key will acknowledge alarms, supervisory and troubles while in their respective events screen. The panel has alarm and trouble resound with lamp flash on subsequent events with alphanumeric annunciation. The flashing lamp turns steady and the local sounder is silenced once all events have been acknowledged.

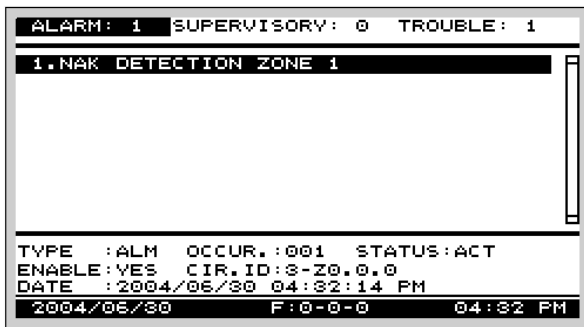

As shown above, before any event is acknowledged, the Alphanumeric Display shows the three letter code 'NAK' in front of the event description. Once acknowledged by the user, this code changes to 'ACK'.

By default, each event has to be acknowledged independently. The user can define in the TECHNICAL SETUP - PARAMETERS menu that holding the key for 2 seconds will acknowledge all the current category of events at once. When this feature is enabled, a second beep will confirm the command has been executed and all events will display the code 'ACK'.

**ALARM SILENCE / ACTIVATE:** When alarms are sounding, pressing once on this key will turn off all the audible devices connected to the silenceable Notification Appliance Circuits (but not the Releasing Circuits). The AUDIBLES SILENCE lamp will illuminate.

When alarms are not sounding, pressing and holding the key for 2 seconds will activate the Alarm Condition, the Notification Appliance Circuits and the System Alarm Relays but not the Releasing Circuit(s). The ALARM ACTIVATE function of the key is always available and both functions are latching, so will require a SYSTEM RESET to clear.

**SYSTEM RESET:** The SYSTEM RESET key will only operate while the system is either displaying a normal operating screen for lamp test or once all events in the System Event Screens have been acknowledged. Trying to reset the system while any event is still not acknowledged will silence the system buzzer momentarily, then make it beep twice and finally continuously again. Once all events are duly acknowledged, a full reset sequence should take only a few seconds to complete.

Under normal conditions, pressing on the SYSTEM RESET key make the local sounder beep once and will also perform a LAMP TEST function.

Under alarm, supervisory or trouble conditions, once all events have been acknowledged and cleared, pressing once on this key resets the system and breaks power to all initiating device circuits, 4-wire smoke power and option boards. It will also clear any activated output circuits. Should any alarm or trouble still exists after the reset, they will automatically re-activate the panel (subsequent alarm function).

### 3. Keyboard - Menu Navigation Keys

**UP / PREVIOUS:** Pressing on this key once will scroll up the highlight to the PREVIOUS line on the Alphanumeric Display or increase the value of a digit. Pressing and holding the key will scroll fast up through the values of a digit.

**DOWN / NEXT:** Pressing on this key once will scroll down the highlight through the NEXT line on the Alphanumeric Display or decrease the value of a digit. Pressing and holding the key will scroll fast down through the values of a digit.

**LEFT ARROW:** Pressing on this key once will scroll the cursor (underscore) sideways to highlight the PREVIOUS digit or field on the Alphanumeric Display.

**RIGHT ARROW:** Pressing on this key once will scroll the cursor (underscore) sideways to highlight the NEXT digit or field on the Alphanumeric Display.

Every time a valid navigation key is depressed, the local sounder will beep once. Holding the UP or DOWN key depressed for 2 seconds will return the cursor (highlight on the active item) directly up to the first or last item or field of any list, depending on the key selected.

The UP or DOWN keys will also scroll up or down a full page in a list of items, thus accelerating navigation when used the same way.

Depressing the same key again when already at the beginning or the end of a list will make the local sounder beep twice to indicate an invalid entry. Any invalid entry will also make the sounder beep twice.

**ENTER:** This key is used to make and confirm choices in the various user menus. It is also used to validate an entry or select an option.

While within the System Normal or System Event screens, pressing and holding the ENTER key for 2 seconds will give access to specific system data screens.

First screen displays the SENSORS LIST / TEMPERATURE as shown below, where up to 6 sensors pressures can be displayed. The cursor also highlights the screen name being accessed in the first line as shown below:



SENSORS LIST BATTERY INFO TIMER STATUS	
NAME	VALUE
[50.1] AIR PRESSURE	2330 PSI
[50.2] SENSOR 2	0 PSI
[50.3] SENSOR 3	0 PSI
<b>TEMPERATURE</b>	
OUTSIDE CABINET TEMP.	61 FAHREN.
2005/04/05 F:0-0-0 03:03 PM	

System Temperature is displayed in the lower part of this screen. Trouble signal will be activated on high or low temperature indications (levels are factory defined). This value is used for system performance analysis and should not be used as a thermometer.

While in this screen, pressing on the RIGHT or LEFT keys will scroll to display the BATTERY INFO. / GROUND FAULT status screen or the TIMER STATUS screen as shown below.

SENSORS LIST BATTERY INFO TIMER STATUS	
BATTERY VOLTAGE	: 24.0 VDC
BATTERY CURRENT	: 2.2 A
BATTERY SIZE	: 24AH
CHARGING MODE	: CHARGING
TIME	: 00:06:41
<b>GROUND FAULT STATUS</b>	
GROUND FAULT	: NORMAL
2004/06/07 F:0-0-0 03 27 PM	

In the BATTERY INFO screen the upper portion of the screen displays the actual battery voltage, current and size. A minus sign in the Battery Current indication shows battery load when the system is powered by the batteries:

- BATTERY SIZE is displaying the value entered initially at the factory or by the user. Refer to MENUS – BASIC SETUP for additional details. CHARGING MODE is also displayed in this section as per the current status of batteries:
- TRICKLE indicates a fully loaded battery on low charge mode.
- CHARGING indicates a low battery condition on high charge mode and will also display a timer showing how long the condition has been active.
- DISABLE is displayed whenever the charger is turned off. This condition appears when system is in alarm state, when a battery fault has occurred or when AC power is off.
- TEST indicates that the batteries are in the system's Automatic Battery Test mode (after a cold start or 30 days after last test). This mode also displays a timer showing how long the condition has been active. If a bad condition of battery is detected, system will go on trouble condition.

The bottom section's GROUND FAULT STATUS indication is for technician use and displays factory codes on Ground

Fault condition for troubleshooting purposes. Refer to TROUBLESHOOTING section for additional details.

In the TIMER STATUS screen, all the set values of the various timers are displayed as shown in the example below (actual screen may differ depending on system configuration):

SENSORS LIST BATTERY INFO TIMER STATUS	
PRE-DISCHARGE	00:00
SHUTDOWN BYPASS	00:00
SOAK TIMER	00:00
WAIT TIMER	00:00
2004/06/18 F:0-0-0 01:36 PM	

Pressing on the MENU/EXIT key will exit the display altogether and return to the default screen.

**Note:** Next time the user will access this display, system will automatically return to the last screen it was displaying before exiting, making a quick return to the same data much easier.



**MENU / EXIT:** Pressing and holding this key for 2 seconds activates the user menu screen on the Alphanumeric Display and when pressed once within a menu item, is used to exit from this menu item. To exit from the menu entirely, press and hold the key for 2 seconds. Typically, the display will automatically return to its default mode if no key activity is detected for a period of about 5 minutes.

Once modifications have been done in a menu section, exiting the menu will save all the new data for the entire section in the system's memory. Individual items don't need to be saved individually.

#### 4. Keyboard - Function Keys



These three keys are configured for special functions adapted to the ICAF system mode, but their programming is not accessible to the user and is made at the factory. The keys functions are only available to the user when in the Normal Screen and while navigating through the System Events Screen.

**Note:** The keys usage is also contextual – depending on the menu or utility, they can be used to perform other systems related functions.

- F1: INSPECTION LOG is used in conjunction with the ARC-1 PC Interface software. It is used at the factory for testing complex sequence of operations with the help of a PC connected to the system, by setting up a flag in the sequence of operation. Once the sequence of operation is activated, the PC will display all the events that occurred between the activation and the de-activation of this flag, making complex sequences verification easier. The log can also be printed for archiving.

Pressing on the key will illuminate the LOG ACTIVATED LED adjacent to the switch.

- F2: Not used.
- F3: SYSTEM SHUT-OFF is a special function associated with ICAF Extinguishing systems. Pressing on this function key anytime during the discharge sequence and then manually closing the water main supply control valve will completely stop the flow of the foam agent. The SHUT-OFF KEY ACTIVATED LED adjacent to the switch will be illuminated while the function is active.

Typically, to activate any function press and hold the key for 2 seconds. Press and hold the key again to return to its normal status. Key status will also be indicated on the alphanumeric display bottom section as described earlier.

### 5. Local Alphanumeric Display

The **ARC-1®** Analog Release Controller is provided with a local Alphanumeric Display, Model LAA, mounted on the front door that provides detailed indications for status display, operation and programming of the system. It is provided with a soft membrane keyboard accessible by opening the front key locked door. The alphanumeric display and the main indicating lamps are visible through the door window at all times.



Upon initial power up, the local sounder will be heard for 2 seconds then will automatically stop. At the same time, the Alphanumeric Display will become momentarily blank and then will show a scrolling "System Reset" indication. It will also momentarily display the "P&P in Progress" indication while the system's Plug and Play routine is executed.

**Note:** The Plug & Play routine is automatically verifying system integrity and module placement at both the initial start-up and system reset.

The start-up procedure should last only a few seconds, after which, if the system is back under normal condition, the Alphanumeric Display will show the System Normal screen, similar to the one shown below:

**Note:** Should the start-up routine take more than 2 minutes and system seems to be hung, perform a cold reset by removing power to the unit and back. If problem continues, contact your nearest FireFlex Authorized Distributor.

This screen displays the system configuration description such as Fixed Discharge System in the example above and the system status in a black window.

The black bottom line typically shows current date and time on the left and right respectively. In the center, the Function Keys status indicator code displays status of an activated function for the corresponding key: A "1" indicates a function is activated by Function Key F1, a "2" for F2 and a "3" for F3. No change or a "0" indicates that the function key(s) is(are) normal or not, assigned to any special function. Refer to paragraph 4 for additional details.

Depending on the specific menu screen, an alternate bottom black line shows number of alarms, supervisory and trouble events, followed by the current date and time when an event is present.

**Note:** All the Alphanumeric Display screens shown throughout this manual are typical and for general information only. Actual screen details may vary depending on selected configuration and conditions.

Time and date on initial start-up will show default values and will have to be adjusted by the user (see MENUS – ACCESS LEVEL 2 for detailed instructions). Furthermore, time and date will return to the last event values in memory every time the system power is completely removed (both AC and battery stand-by).

Upon any event, the System Normal screen will change to the System Event screen and show all current events and their status.

Shown below is a flow chart describing in which order the system keys must be operated in case of various events:

#### SINGLE EVENT OPERATION:

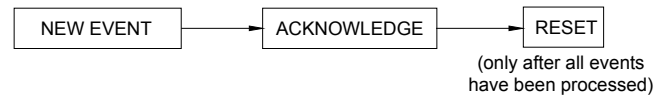

#### MULTI EVENTS OPERATION:

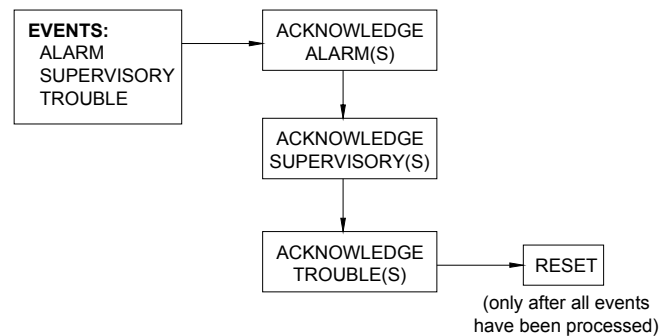

Here is a simulated System Event screen illustrating the various displays:

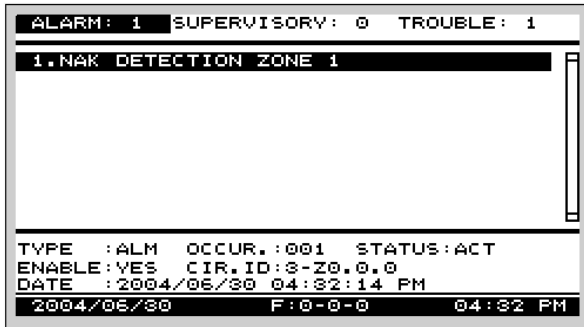

The first line in the screen gives the number of events per category in the following priority: Alarm, Supervisory and Trouble. Scrolling through the three categories is done using the following keys:



Pressing on the RIGHT ARROW key will move the highlight to the next category of events at the right, i.e.: from Alarm to Supervisory or from Supervisory to Trouble. When doing so, events of the highlighted category will be listed below.



Pressing on the LEFT ARROW key will move the highlight to the previous category of events at the left, i.e.: from Trouble to Supervisory or from Supervisory to Alarm. When doing so, events of the highlighted category will be listed below.

**Note:** The same function is applicable whenever the first line of the display shows a few choices with one highlighted as shown in the figure above.

Current events are displayed in the list, identified as 'NAK' for Not Acknowledged, or 'ACK' for Acknowledged, the first event remaining highlighted until acknowledged. Up to 99 events are displayed per screen – (for the full list of events, use the EVENTS LOG). Note the cursor at the right side of the screen. The position of the black square indicates how far in the list the display has gone.

Next is the technical section, displaying various data for the highlighted event:

**TYPE** is a three letter code displaying which type of event is highlighted where:

- ALM = Alarm
- TBL = Trouble
- SUP = Supervisory
- NOP = Not Operated.

**OCCUR** displays the number of occurrences of the event, which is particularly useful in case of intermittent events to see how many times the event occurred. Total number of occurrences displayed in the even log is factory limited:

- Alarms: 5
- Supervisory: 4
- Troubles: 3

**STATUS** shows the actual status of the circuit where:

- ACT = Active
- NRM = Normal.

**ENABLE** indicates if the circuit is Enabled (yes) or Disabled (no).

**CIR.ID** displays a 5 digit code used by the factory, describing module placement, circuit type, zone number and type of activation. Refer to TROUBLESHOOTING in Appendix D for additional details on these codes.

**DATE** displays the date and time stamp at which the highlighted event occurred.

**Note:** Alarms have priority and will always override any other event. The alarm screen will always display first and over any other screen that might be displayed at the time of the alarm.

### System Sequence of Operation

**IMPORTANT NOTICE !** The detailed sequence of operation described below is specifically written for your application. Other system's operation may differ greatly depending on the system's requirements and particulars of the projects.

Always refer to the Sequence of Operation provided with your unit for precise information.

The heat detectors are wired on two zones for operation in crossed zones mode.

**The activation of EITHER detection zones will cause the following:**

On the Control Panel Annunciator:

- the zone in alarm will be displayed.
- the ALARM LED will flash
- the local buzzer will sound.

System Output Activation:

- an ALARM contact for the ALARM transmission to the Main Fire Alarm Building panel will be activated.
- an ALARM signalling circuit will be activated.

**The activation of BOTH detection zones (crossed zones) will cause the following:**

On the Control Panel Annunciator:

- the zones in alarm will be displayed.
- the ALARM LED will flash
- the local buzzer will sound.
- the Release LED will illuminate
- the Discharge LED will illuminate

System Output Activation:

- an ALARM contact for the ALARM transmission to the Main Fire Alarm Building panel will be activated.
- an ALARM signalling circuit will be activated.
- the release circuit will be activated and the CAF discharge will occur.
- the DISCHARGE contact will be activated for auxiliary function.

**The activation of electrical emergency manual release station will cause the following:**

On the Control Panel Annunciator:

- the zone in alarm (MANUAL PULL) will be displayed.
- the ALARM LED will flash
- the local buzzer will sound.
- the Release LED will illuminate.
- the Discharge LED will illuminate

### System Output Activation:

- an ALARM contact for the ALARM transmission to the Main Fire Alarm Building panel will be activated.
- an ALARM signalling circuit will be activated.
- The release circuit will be activated and the CAF discharge will occur.
- The DISCHARGE contact will be activated for auxiliary function.

### **The activation of mechanical emergency manual station inside the ICAF cabinet will cause the following:**

#### On the Control Panel Annunciator:

- the zone in alarm (WATERFLOW) will be displayed.
- the ALARM LED will flash
- the local buzzer will sound.
- the Discharge LED will illuminate

#### System Output Activation:

- an ALARM contact for the ALARM transmission to the Main Fire Alarm Building panel will be activated.
- an ALARM signalling circuit will be activated.
- the CAF discharge will occur and the DISCHARGE contact will be activated for auxiliary function.

### **Automatic Discharge**

The CAF discharge will occur for 10 minutes. At the end of the soak timer, the CAF discharge will automatically stop. The Release LED will then start flashing.

### **Emergency discharge Shut-Off**

Because the ICAF System cannot be turned off by the operation of a single valve as is the case for a standard sprinkler system, a manual shut-off function is provided. The CAF discharge can be manually suspended using the following sequence of operation:

1. Press and hold the function key F3 labelled: "System Shut-Off" on the keypad of the ARC-1 panel until its adjacent red lamp is turned On.
2. Close the system main water supply valve inside the ICAF cabinet. The red lamp labelled "Discharge suspended" will turn On.

**Note:** Mechanical emergency release valve must be in normal position prior the CAF discharge shut-off.

**IMPORTANT:** After a fire, make sure it is completely extinguished. If necessary, place a fire patrol in the zone covered by the system. Foam systems that have been subjected to fire must be returned to service as soon as possible. The entire system must be inspected for damage, and repaired or replaced as necessary.

**Warning!** DO NOT CLOSE THE WATER SUPPLY TO MAKE REPAIRS WITHOUT PLACING A FIRE PATROL IN THE AREA COVERED BY THE SYSTEM. THE PATROL SHALL REMAIN THERE UNTIL THE SYSTEM IS BACK IN OPERATION. Advise local authorities of the necessary work over the fire protection equipment. Follow emergency procedures required by codes and the Authority Having Jurisdiction during system maintenance.

**Note:** BEFORE CLOSING A VALVE OR ACTIVATING AN ALARM, ADVISE THE SECURITY GUARD AND THE CENTRAL SUPERVISORY STATION. THIS IS TO AVOID DISPATCHING THE FIRE DEPARTMENT IN CASE OF A FALSE ALARM.

### **Inspection Log**

The function key F1 labelled "Inspection Log" is used in conjunction with the ARC-1 Remote Interface software for PC.



# ICAF – Integrated Compressed Air Foam System

## Controls Section

### System Wiring Details

The following is a detail of the modules provided with this system and their placement location followed by the wiring diagrams of each of these modules.

#### ICAF System Modules Placement Detail:

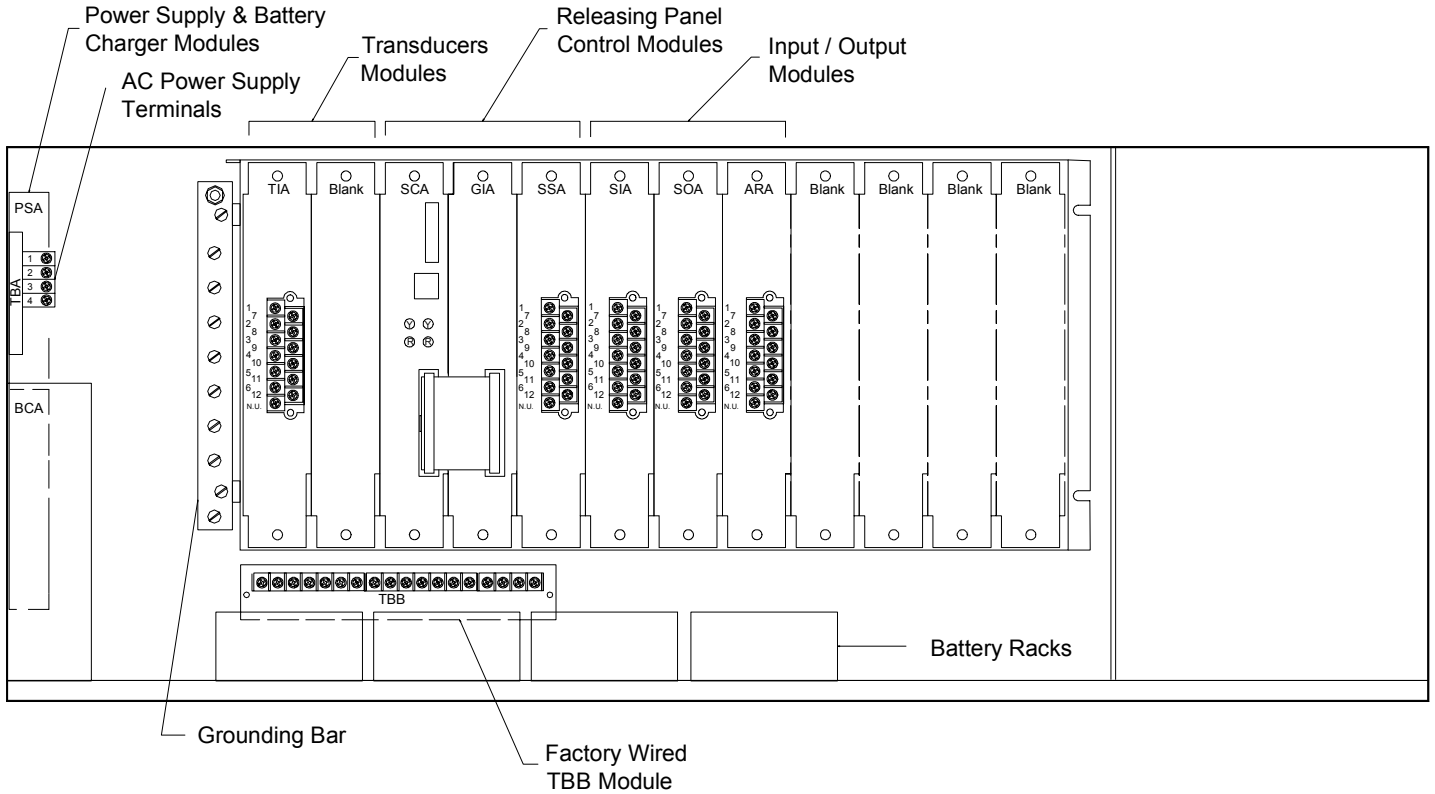

#### SSA Module – System Supervisory Circuits:

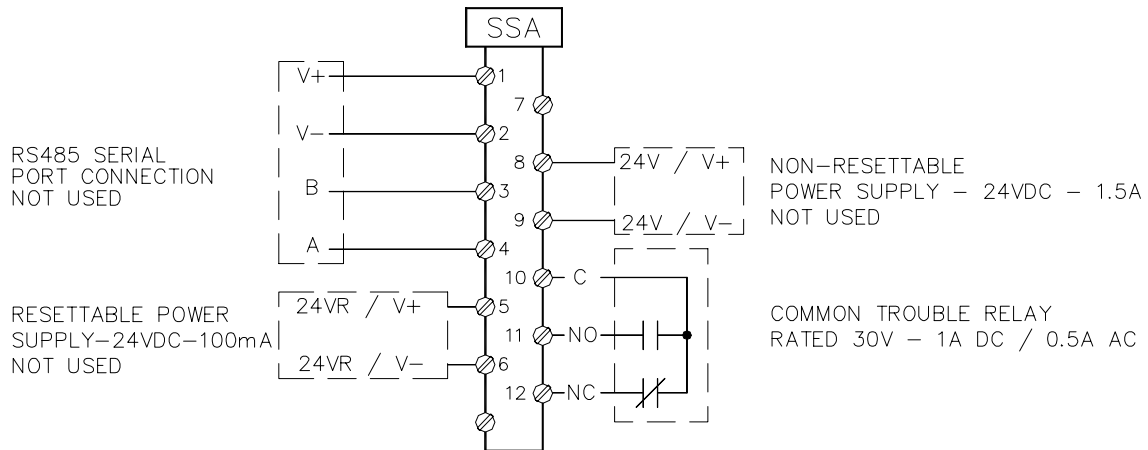

### TIA Module – Pressure Transducers Interface:

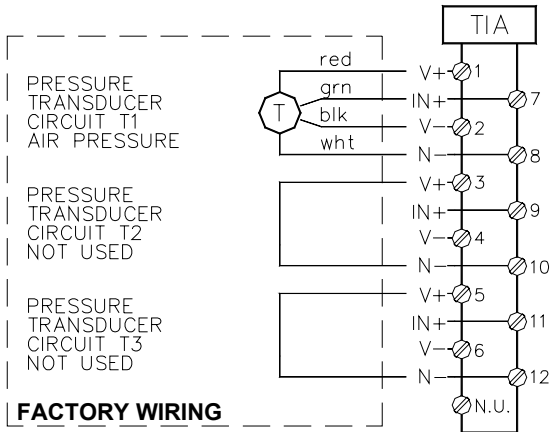

### SIA Module – Supervised Input Zones:

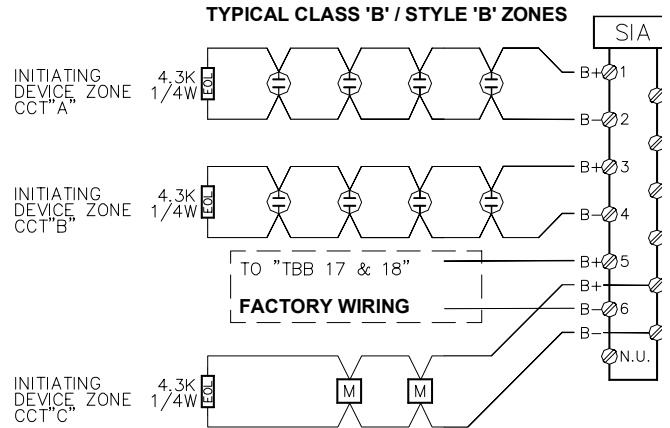

### SOA Module – Supervised Output Circuits:

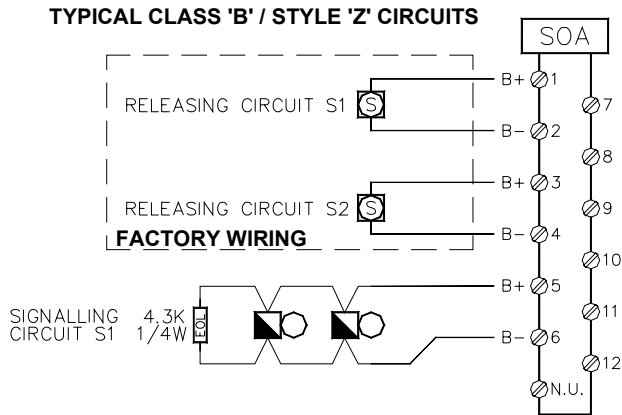

### TBA Factory Wiring Terminal Strip:

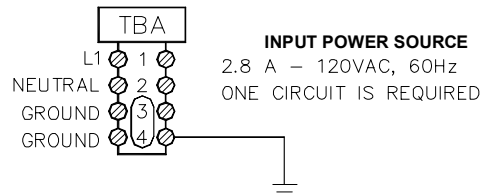

Wiring size: Minimum 14 AWG with 600 V insulation.

### TBB Factory Wiring Terminal Strip:

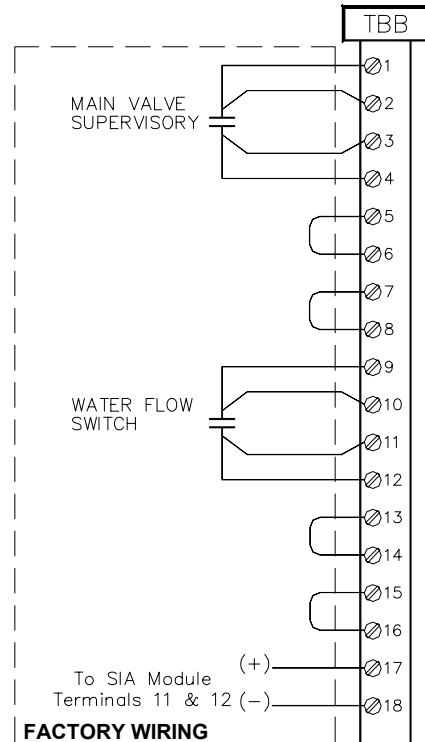

### ARA Module – Auxiliary Relay Outputs:

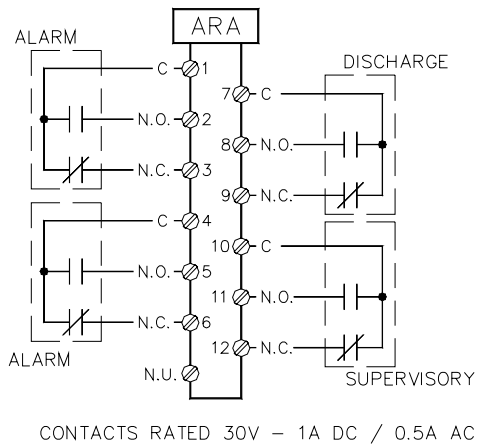



# ICAF - Integrated Compressed Air Foam System

## System Trim Section

### ICAF System with Electric Fail-safe Release

#### 1. Description

The **ICAF** System utilizes a Flow Control valve (*B14*) to control water flow into system piping equipped with open rotating spray nozzles. The system piping remains empty until the Flow Control Valve is activated by operation of the release system.

In fire condition, when the detection condition is satisfied the ARC-1 Control Panel energizes the Solenoid Valve (*R2*) open, the pneumatic control line is then pressurized causing the water, air and foam pneumatically activated control valves (*A1*, *B9* & *F1*) to open simultaneously and generate the CAF through a piping system into the discharge devices and to be discharged over the area served by the discharge devices.

*Electric Fail-Safe Release* means that if the AC Power fails and the battery backup expires while the system is operating, the system will fail-safe, and continue flowing until AC Power is restored or the system is manually shut-off

#### 2. Normal conditions

1. ARC-1 Control panel of the ICAF System:
  - a) Green LAMP for power is activated in continuous manner.
  - b) All other LAMPS are deactivated.
  - c) Alpha-numeric Display shows default screen "SYSTEM NORMAL"
2. Valves:
  - a) Main water supply control valve (*B10*) is OPEN.
  - b) All upstream water supply valves are OPEN.
  - c) Priming valve (*B1*) is OPEN.
  - d) Flow test valve (*B6*) is CLOSED.
  - e) System main drain valves (*B16*) are CLOSED.
  - f) Alarm test valve (*B5*) is CLOSED.
  - g) Manual emergency release valve (*R1*) is CLOSED (handle in NORMAL position).
  - h) System flushing valve (*A3*) is CLOSED.
  - i) Foam injector flushing valve (*F5*) is CLOSED.
  - j) All gauge valves are OPEN.
3. Gauges:
  - a) Water supply (*B12*) - at water supply pressure
  - b) Priming chamber (*B11*) - should be equal to, or higher than, water supply pressure (*B12*).
  - c) Air supply pressure (*A4*) is between 100-135 psi.
  - d) Foam injection line pressure is 0 psi.
4. Air supply:
  - a) Air supply is in NORMAL condition (see Air Supply section for details).
5. Foam supply:
  - a) Foam supply is in NORMAL condition (see Foam Supply section for details).

REFER TO NEXT PAGE TO VIEW TRIM SCHEMATIC.



# ICAF - Integrated Compressed Air Foam System

## System Trim Section

### Trim Schematic: System with electric fail-safe release

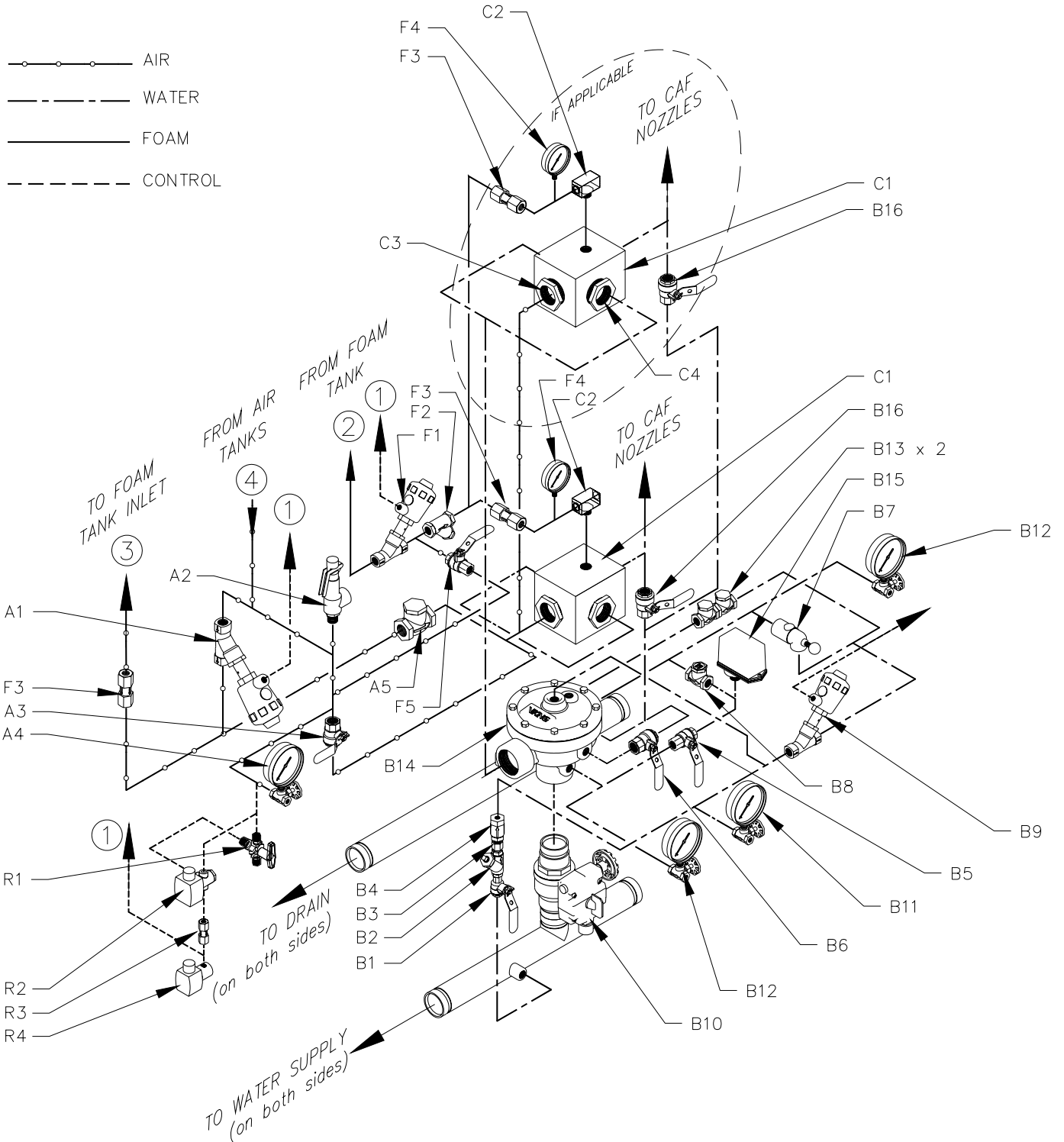

FM-072C-0-270 A





# ICAF - Integrated Compressed Air Foam System

## System Trim Section

### Trim Components:

#### A. AIR SUPPLY:

- A1 Air pneumatically operated control valve (N.C.)
- A2 Safety valve
- A3 System flushing valve
- A4 Air supply pressure gauge & valve
- A5 Clapper check valve

#### B. WATER SUPPLY:

- B1 Priming valve
- B2 'Y' Strainer
- B3 1/8" Restricted orifice
- B4 Spring loaded check valve
- B5 Alarm test valve
- B6 Flow test valve
- B7 Drip check valve
- B8 Drain check valve
- B9 Water pneumatically actuated control valve (N.C.)
- B10 Water supply control valve
- B11 Priming pressure water gauge & valve
- B12 Water supply pressure gauge & valve
- B13 Clapper check valve
- B14 Flow control valve
- B15 Alarm pressure switch
- B16 Main drain valve

#### C. CAF MIXING CHAMBER:

- C1 Mixing chamber
- C2 Foam injector
- C3 Air injector
- C4 Water injector

#### R. RELEASE SYSTEM:

- R1 Emergency release valve
- R2 3-Way N.C. 24Vdc solenoid valve (actuation)
- R3 Spring loaded check valve
- R4 N.C. 24Vdc solenoid valve (vent)

#### F. FOAM SUPPLY:

- F1 Foam pneumatically actuated control valve (N.C.)
- F2 Foam injection line 'Y' strainer
- F3 Spring loaded check valve
- F4 Foam injection line pressure gauge
- F5 Foam injector flushing valve



### Air Supply Section

Compressed Air Foam is composed of 90% compressed air. This air is provided by DOT and TC certified compressed air cylinders (C2) pressurized to 2,400 psi (16,536 kPa). Each cylinder is supplied with a cylinder valve (C4) equipped with a safety relief disc (C3), which provides relief at 3600-4000 psi.

Factory adjusted air pressure regulators (C5) are used to reduce the storage air pressure to a working pressure of 100 psi (689 kPa) for the system operation.

The cylinders bank pressure is supervised by a pressure transducer (C7) that sends a low pressure supervisory signal when storage pressure goes under 2200 psi (15,158 kPa). That pressure represents the minimum pressure required to provide air supply for the specified system discharge time.

A safety valve (A2 - mounted in the cabinet) is also used at the outlet of the air pressure regulator (C5) to protect the system from high pressure in case of malfunction. The working air pressure on the system side (downstream of the air regulator) is adjusted to a maximum of 150 psi (1034 kPa).

The cylinders bank is factory assembled on a painted steel skid and includes the cylinders, support brackets, valves, high pressure tubing, discharge manifold (C8) and all the necessary hardware.

Cylinder Valve Guards (not shown) are used instead of cylinder caps, eliminating the repetitive costs associated with the use of cylinder caps. These guards protect the cylinder heads during shipment, therefore no protective caps have to be removed and most importantly, no tubing or fittings are required to be installed after receiving.

The cylinders bank is also provided with a refilling outlet (C9), which allows refilling the complete bank on-site with a high pressure compressor, without having to remove any other parts or having to transport the cylinders to a filling plant.

The skid mounted cylinders bank is available with single or twin pressure regulator (C5) assemblies and is available in the following storage capacities:

- up to 4 cylinders
- up to 6 cylinders
- up to 8 cylinders
- up to 10 cylinders
- up to 12 cylinders

#### 1. Air supply design and selection:

The number of cylinders (C2) and regulators (C5) established at the design stage is based on both the maximum system flow and discharge time required for the largest single hazard protected or group of hazards that are protected simultaneously. FireFlex's program will take that into account when calculating the system's capacity.

**Note regarding air cylinders:** The calculated number of compressed air cylinders is based on a storage temperature of 70°F (21°C), for a storage temperature range between 60°F and 80°F (15.5°C and 26.6°C). Any storage temperature outside this range must be taken into consideration during system design phase.

#### 2. Interconnection Piping to ICAF System

There is one interconnection line (item 4) provided on all air cylinders banks. This connection is used to supply compressed air between the cylinders bank and the ICAF System. Piping is factory prepared according to installation arrangement and is supplied with the system.

Fig. 1 - Cylinders Bank dimensions & capacity:

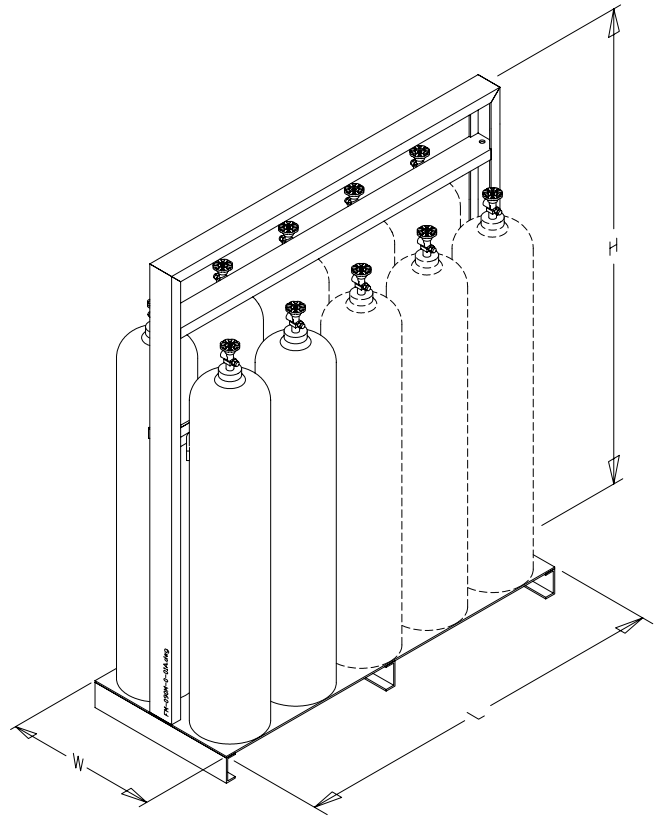

Storage Capacity Nbr of cyls.	Dimensions (inches)		
	Width	Length	Height
4	24	24	82
6		36	
8		48	
10		60	
12		72	

### 3. Operation

- .1 To OPEN Air Supply:
  - a Before opening any cylinder valve, verify that the piping between the cylinder bank and the ICAF System is properly installed and secured.
  - b Slowly open one cylinder valve (C4) and check for any leak between the cylinder valve, the manifold and the ICAF System air supply line (*circled item 4*). If there is no leak, pressure will build up in the manifold and the piping.
  - c Once pressure is stabilized, pressure gauge (C6) should indicate a minimum pressure of 2200 psi. and pressure transducer (C7) should indicate a normal status at the ARC-1 Release controller.
  - d Air pressure gauge (A4) inside the ICAF System cabinet should indicate a pressure of 100 psi. Refer to TRIM SCHEMATIC section.
  - e Open all of the remaining cylinders.
- .2 To CLOSE air supply:
  - a Close all cylinders valves (C4).
  - b Bleed system manifold and air supply line by opening system flushing valve (A3). Refer to TRIM SCHEMATIC section.

### 4. Recharge cylinders:

After a system discharge or when cylinder pressure is under the minimum recommended pressure, cylinders must be refilled with dry air to a storage pressure of 2400 psi @ 70°F (16,536 kPa @ 21°C). The following steps must be followed before sending the cylinders for refilling.

- a Close all cylinder valves (C4).
- b Bleed system manifold and air supply line by opening system flushing valve (A3). Refer to TRIM SCHEMATIC section.
- c After all the pressure is removed, pressure gauge (C6) should indicate a pressure of 0 psi.
- d Remove pressure regulator assembly (C5) and pressure gauge (C6).
- e Properly plug manifold outlet to prevent any dirt from contaminating manifold during transport.

**NOTICE:** Empty cylinders must be recharged by FireFlex or its trained authorized agent. Contact FireFlex After Sales Support Department for information about the nearest authorized agent to your location.

### 5. Maintenance and inspection:

Regular inspections, tests, and maintenance should be performed at intervals specified in this document to verify that the air supply is in good operating condition and that it functions as intended.

#### Cylinder inspection:

Storage air pressure shall be checked at least semi-annually. If the air cylinders bank shows a pressure under 2200 psi. it shall be refilled or replaced.

#### Hydrostatic test:

High-pressure cylinders used in ICAF systems shall not be recharged without a hydrostatic test (and remarking) if more than 5 years have elapsed from the date of the last test. Cylinders continuously in service without discharging shall be permitted to be retained in service for a maximum of 12 years from the date of the last hydrostatic test. At the end of 12 years, they shall be discharged and retested before being returned to service.

Cylinders continuously in service without discharging shall be given a complete external visual inspection every 5 years or more frequently if required. The visual inspection shall be in accordance with Section 3 of CGA C-6, Standard for Visual Inspection of Steel Compressed Gas Cylinders, except that the cylinders need not be emptied or stamped while under pressure. Inspections shall be made only by competent personnel and the results recorded on both of the following:

- (1) A record tag permanently attached to each cylinder
- (2) A suitable inspection report

A completed copy of the inspection report shall be furnished to the owner of the system or an authorized representative. These records shall be retained by the owner for the life of the system.

Where external visual inspection indicates that the container has been damaged, additional strength tests shall be required.



**Figure 2 – Compressed Air Cylinders Bank**

(Rack mounted)

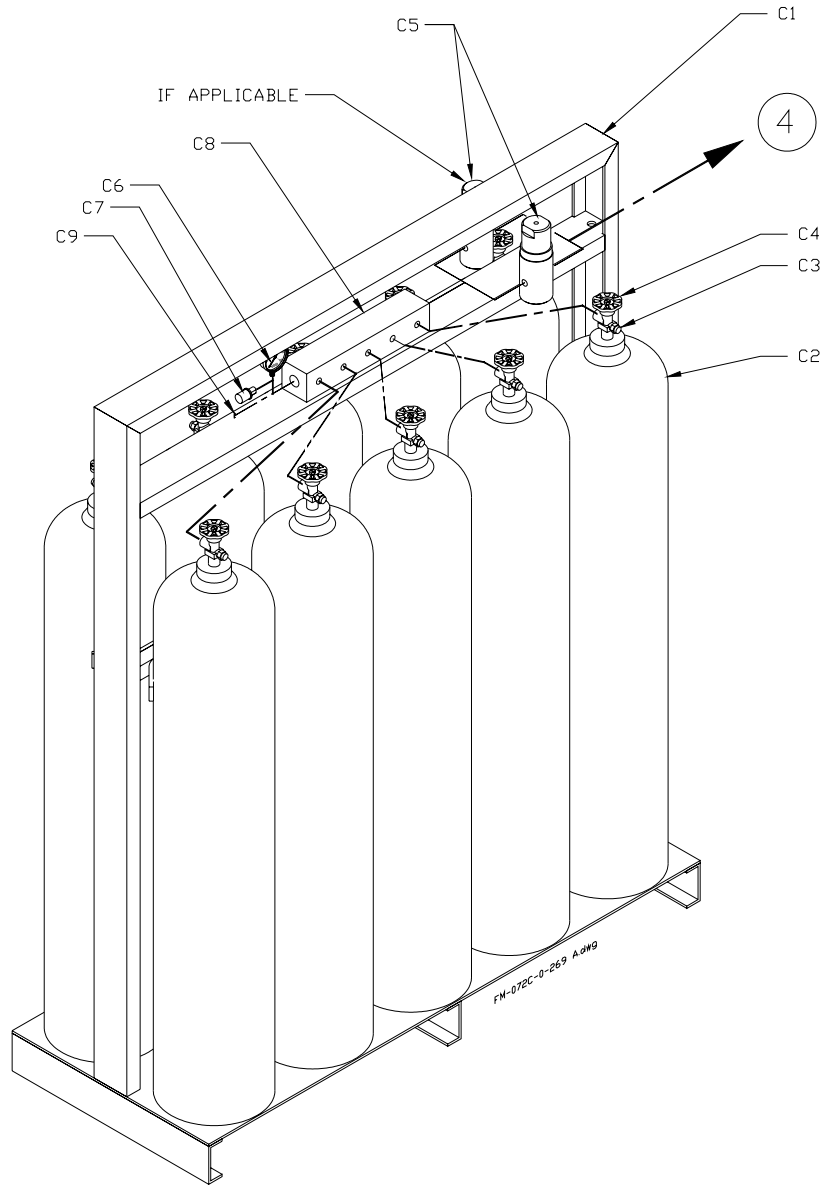

**Air supply Components:**

- |    |                         |    |                        |
|----|-------------------------|----|------------------------|
| C1 | Cylinders rack          | C5 | Pressure regulator     |
| C2 | Compressed air cylinder | C6 | Pressure gauge         |
| C3 | Safety release disk     | C7 | Pressure transducer    |
| C4 | Cylinder valve          | C8 | High pressure manifold |
|    |                         | C9 | Refilling outlet       |

### Foam Supply Section

#### 1. Foam Storage Tank

Foam concentrate is stored inside a stainless steel pressure vessel type tank (T1) stamped according to ASME Section VIII Div. 1. Storage tank is normally unpressurized; maximum working pressure is 150 psi (1033 kPa). The tank is supplied with a safety relief valve (T8) set at 135 psi (930 kPa) for protection against over-pressurization.

Foam storage tank is factory assembled and includes all the valves, trim and hardware as shown on Figure 2. Manual valves are provided to fill the tank (T9) with foam concentrate and to release the air pressure (T6) after a CAF discharge. A sight gauge (T5) is also provided to allow visual verification of the tank foam concentrate normal level.

#### 2. Foam Concentrate

CAF system shall be used with the following foam concentrates and concentrations:

Foam concentrate	Concentration
<i>Hydrocarbons</i>	
National Foam Aer-O-Lite 3%	2%
National Foam Aer-O-Water 3EM 3%	2%
<i>Polar Solvents</i>	
Ansul Ansulite 3X3 LV	6%

#### Shelf Life

The shelf life of any foam concentrate is maximized by proper storage conditions and maintenance. Factors affecting shelf life are wide temperature changes, extreme high or low temperatures, evaporation, dilution, and contamination by foreign materials. Properly stored foam concentrates have been tested and shown no significant loss of fire fighting performance, even after 15 years. For further details, see the Foam Concentrate Data Sheet.

#### Environmental and Toxicological Information

Foam concentrates used with Compressed Air Foam Systems are biodegradable. However, as with any substance, care should be taken to prevent discharge from entering ground surface water, or storm drains. Since facilities vary widely by location, disposal should be made in accordance with federal, state and local regulations. For further details, see the foam Concentrate Data Sheet and Material Safety Data Sheet.

#### 3. Foam tank design and selection

The capacity established at the design stage is based on both the maximum system flow and discharge time required for the largest single hazard protected or group of hazards that are protected simultaneously; FireFlex's design software will take that into account when calculating the system's capacity.

Consequently, multiple foam tanks can be installed in parallel to satisfy project requirements.

#### 4. Interconnection Piping to ICAF System

There are two interconnection lines provided on all foam storage tanks. One connection is used to pressurize the foam storage tank with compressed air (circled item 3), the other to provide foam concentrate to the mixing chamber (circled item 2). Piping between the foam storage tank and the ICAF System is factory prepared according to the installation arrangement and supplied with the system.

Figure 1 - Storage tank dimensions & capacity:

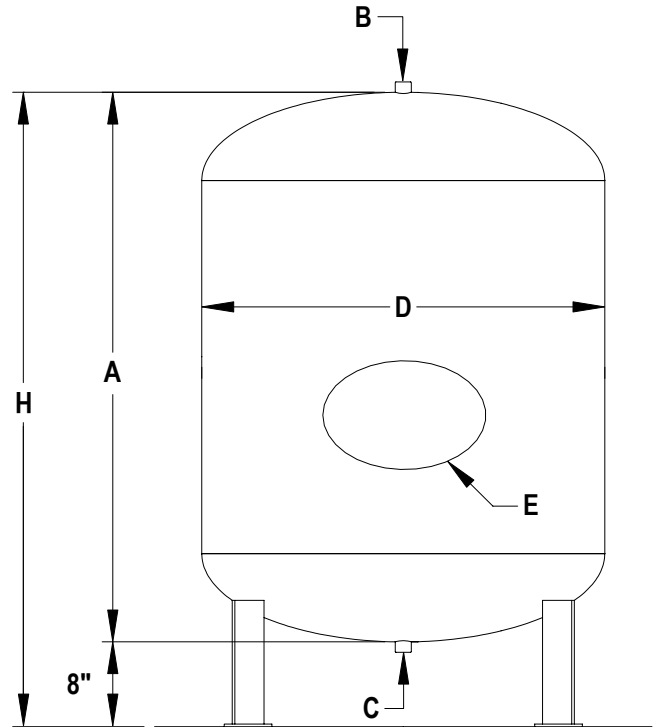

Nominal Capacity USGal	Dimensions (in)			Outlet (NPTF)		Manhole
	A	D	H	B	C	E
25	35	16	43	1"	1"	N/A
35	23	24	31			
50	33	24	41			
100	66	24	74	2"		
200	54	36	62			
300	67	38	75	3" flange		16" X 12"
400	67	48	75			
450	78	48	86			
500	65	54	73			

### 5. Operation

#### Foam storage tank

The storage tank (T1) contains foam concentrate under atmospheric pressure in normal conditions. Upon actuation of the system, the foam pneumatically activated control valve (F1) opens, pressurizing the storage tank with air and expelling the foam concentrate in the foam injection line through a dip tube (F2). Foam concentrate is then injected in the mixing chamber (C1) through a calibrated orifice (C2) sized to generate CAF in the correct proportions.

#### Foam Tank Normal conditions

Before placing the foam tank in service, verify that the piping between the foam tank and the ICAF System is properly installed and secured.

1. Tank drain valve (T3) is locked CLOSED.
2. Tank refill valve (T9) is locked CLOSED.
3. Tank refill vent valve (T6) is locked CLOSED.
4. Sight gauge isolation valves (T4) are locked CLOSED.
5. Foam tank pressure gauge (T7) shows 0 psi (0 kPa) pressure.

(Refer to Figure 1 for foam storage tank schematic)

#### Sight gauge

The sight gauge (T5) is a device used to provide visual indication of the foam concentrate level in the storage tank (T1) during the system periodic inspections. Sight gauge (T5) shall not show any reading during normal stand-by and operating conditions since both its isolation valves (T4) should be locked CLOSED.

#### Level check procedure:

(Refer to figure 2- Foam storage tank schematic).

Normal inspection: Under normal standby conditions, foam storage tank (T1) is not pressurized. Sight gauge (T5) should not show any reading and tank pressure gauge (T7) should be at 0 psi (0 kPa).

1. Verify that foam storage tank pressure gauge (T7) shows 0 psi (0 kPa) pressure.
2. OPEN both sight gauge isolation valves (T4).
3. SLOWLY OPEN tank refill vent valve (T6), allowing the foam concentrate stored in the tank to reach its level in the sight gauge tube.
4. Check the sight gauge (T5) level:
  - a) **If level is normal**, CLOSE the bottom sight gauge isolation valve (T4) and drain concentrate from level gauge tube by opening the tank drain valve (T3). Once the level gauge tube is drained, CLOSE tank drain valve (T3), both sight gauge isolation valves (T4) and the tank refill vent valve (T6).
  - b) **If level is below normal**, add foam concentrate up to normal level by following FILLING PROCEDURE described in section 6.

#### After a system discharge

Foam storage tank (T1) is pressurized when operated; therefore pressure must be relieved before a sight gauge (T5) reading can be taken after a discharge.

1. To allow air to vent from the foam storage tank, SLOWLY AND PARTIALLY OPEN tank refill vent valve (T6) until tank pressure gauge (T7) indicates 0 psi (0 kPa) pressure.
2. OPEN both sight gauge isolation valves (T4).
3. SLOWLY OPEN tank refill vent valve (T6). This will allow the remaining foam concentrate in the tank to reach its level in the sight gauge tube.
4. Check sight gauge level (T5).
  - a) **If level is normal**, CLOSE the bottom sight gauge isolation valve (T4) and drain concentrate from level gauge tube by opening the tank drain valve (T3). Once the level gauge tube is drained, CLOSE tank drain valve (T3), both sight gauge isolation valves (T4) and the tank refill vent valve (T6).
  - b) **If level is below normal**, add foam concentrate up to normal level by following FILLING PROCEDURE described in section 6.

### 6. Filling Procedure

**NOTICE:** USE ONLY FOAM CONCENTRATE APPROVED FOR FIREFLEX'S COMPRESSED AIR FOAM SYSTEM.

**SAFETY NOTICE:** Foam concentrates are primary eye irritants, and contact with the eyes should be avoided. Users are advised to wear protective equipment when filling foam tank. If foam concentrate enters the eyes, flush them well with water and seek immediate medical attention. For further details, see foam concentrate Material Safety Data Sheet.

1. Before starting the fill procedure, insure that the foam storage tank (T1) is not pressurized. Verify that foam storage tank pressure gauge (T7) shows 0 psi (0 kPa) pressure.
2. Verify that you have in hand the amount of foam concentrate that corresponds to the storage tank rated capacity.
3. Storage Tank Drain Valve (T3) and Level Sight Gauge Isolation Valves (T4) should be closed.
4. Open the Foam Refill Valve (T9) and the Foam Refill Vent Valve (T6).
5. Prime and connect the concentrate pumping apparatus to the Foam Refill Valve (T9). Use a Hand-operated Drum Pump, a Centrifugal Pump or Pneumatic Operated Diaphragm Pump.





## Foam Supply Section

6. Slowly start to pump the concentrate into the storage tank and adjust the flow to avoid concentrate overflows at the Foam Refill Vent Valve (T6).
7. When approximately 90% of the nominal charge has been pumped, stop pumping and open the level sight gauge isolation valves (T4) to check the sight gauge (T5) level.
8. Resume pumping at a very slow rate and stop pumping when level reaches about halfway in the sight gauge.
9. CLOSE bottom sight gauge isolation valve (T4) and drain concentrate from level gauge tube by opening tank drain valve (T3).
10. Once the level gauge tube is drained, CLOSE tank drain valve (T3) and both sight gauge isolation valves (T4).
11. CLOSE the Foam Refill Valve (T9) and the Foam Refill Vent Valve (T6).

### 7. Maintenance and inspections

Regular inspections, tests, and maintenance should be performed at intervals specified in this document to verify that the foam supply is in good operating condition and that it functions as intended. The system shall be so arranged that tests can be performed with as little loss of foam as practical. Components shall be restored to full operational condition following inspection and testing.

#### Foam Tank Normal conditions

Verify that all valves are in the proper position (refer to page 2 and the foam storage tank schematic).

#### Foam concentrate level check

Regular inspections should be performed to verify the concentrate level, follow the level check procedure described on page 2. If the concentrate is lower than recommended, refer to the refilling instructions on page 3.

#### Foam sample analysis

Inspection of foam concentrates and their containers shall be made for evidence of excessive sludging or deterioration. Inspection shall include a qualitative test of the foam concentrate normally conducted by the manufacturer.

Presence of specific quantities of concentrates in system storage equipment in service ready position and quantities of reserve concentrates on hand shall be checked with requirements for same.

Eight ounce (8 oz.) (250 ml) samples of foam concentrate should be taken from the Storage tank drain valve (T3). Foam samples may be sent to FireFlex Systems.

Either glass or plastic bottles are satisfactory, provided they are leak-proof and well packaged. The sample(s) must be labelled and provide the location, type of concentrate, lot number and date, storage container, name and phone number of the person sending the sample(s). The sample(s) will be evaluated for appearance, foam expansion, drain time, and film spread, as compared to foam standards.

#### Foam sample collection procedure:

(Refer to figure 2- Foam storage tank schematic)

Under normal standby conditions, foam storage tank (T1) is not pressurized. Sight gauge (T5) should not show any reading and tank pressure gauge (T7) should be at 0 psi (0 kPa).

1. Verify that foam storage tank pressure gauge (T7) shows 0 psi (0 kPa) pressure.
2. OPEN both sight gauge isolation valves (T4).
3. SLOWLY OPEN tank refill vent valve (T6), allowing the foam concentrate stored in the tank to reach its level in the sight gauge tube.
4. Collect the sample of foam concentrate by opening storage tank drain valve (T3).
5. Once the sample is collected, close the storage tank drain valve (T3).
6. CLOSE bottom sight gauge isolation valve (T4) and drain concentrate from level gauge tube by opening tank drain valve (T3). Once the level gauge tube is drained, CLOSE tank drain valve (T3), both sight gauge isolation valves (T4) and tank refill vent valve (T6).

#### Foam injection line testing procedure

(Refer to TRIM SCHEMATIC in the ICAF System section)

Regular tests should be performed to verify that the foam injection line is not clogged by any debris or coagulated foam concentrate that would impair its proportioning rate.

Under normal standby conditions, foam injection line is not pressurized. Foam injection line pressure gauge (F4) should read 0 psi (0 kPa).

1. System's air supply should be open; air pressure gauge (A4) inside the ICAF System cabinet should indicate a pressure of 100 psi.
2. OPEN foam injector flushing valve (F5).
3. Wait approximately 5 seconds or until pressure stabilizes at the foam injection line pressure gauge (F4).
4. CLOSE foam injector flushing valve (F5).
5. Foam injection line pressure gauge (F4) should vent quickly and indicate 0 psi (0 kPa) after a few seconds.
6. If the foam injection line doesn't vent properly, the foam injector (C2) shall be disassembled, cleaned, and reassembled.



## Foam Supply Section

### Foam injection line post discharge testing procedure

(Refer to TRIM SCHEMATIC in the ICAF System section)

A test should be performed to verify that the foam injection line is not clogged by any debris or coagulated foam concentrate that would impair its proportioning rate.

Under normal standby conditions, foam injection line is not pressurized. Foam injection line pressure gauge (F4) should read 0 psi (0 kPa).

1. System's air supply should be open; air pressure gauge (A4) inside the ICAF System cabinet should indicate a pressure of 100 psi.
2. OPEN foam injector flushing valve (F5).
3. Wait approximately 1 minute or until pressure stabilizes at the Foam injection line pressure gauge (F4).
4. CLOSE foam injector flushing valve (F5).
5. Foam injection line pressure gauge (F4) should vent quickly and indicate 0 psi (0 kPa) after a few seconds.
6. If the foam injection line doesn't vent properly, the foam injector (C2) shall be disassembled, cleaned, and reassembled.

### Foam injection strainer maintenance

Remove, clean and replace foam injection line strainer (F2) screen in original position (Note: In some instances, a high pressure water jet or steam may be required for effective cleaning) Inspect cover gasket for damage. Replace if necessary.

### Inspection Frequency Table

System/Component	Frequency
Foam tank normal conditions	Monthly
Foam concentrate level check	Annually
Foam sample analysis	Annually
Foam injection line test	Quarterly
Foam injection strainer maintenance	Annually





Figure 2 – Foam storage tank schematic:

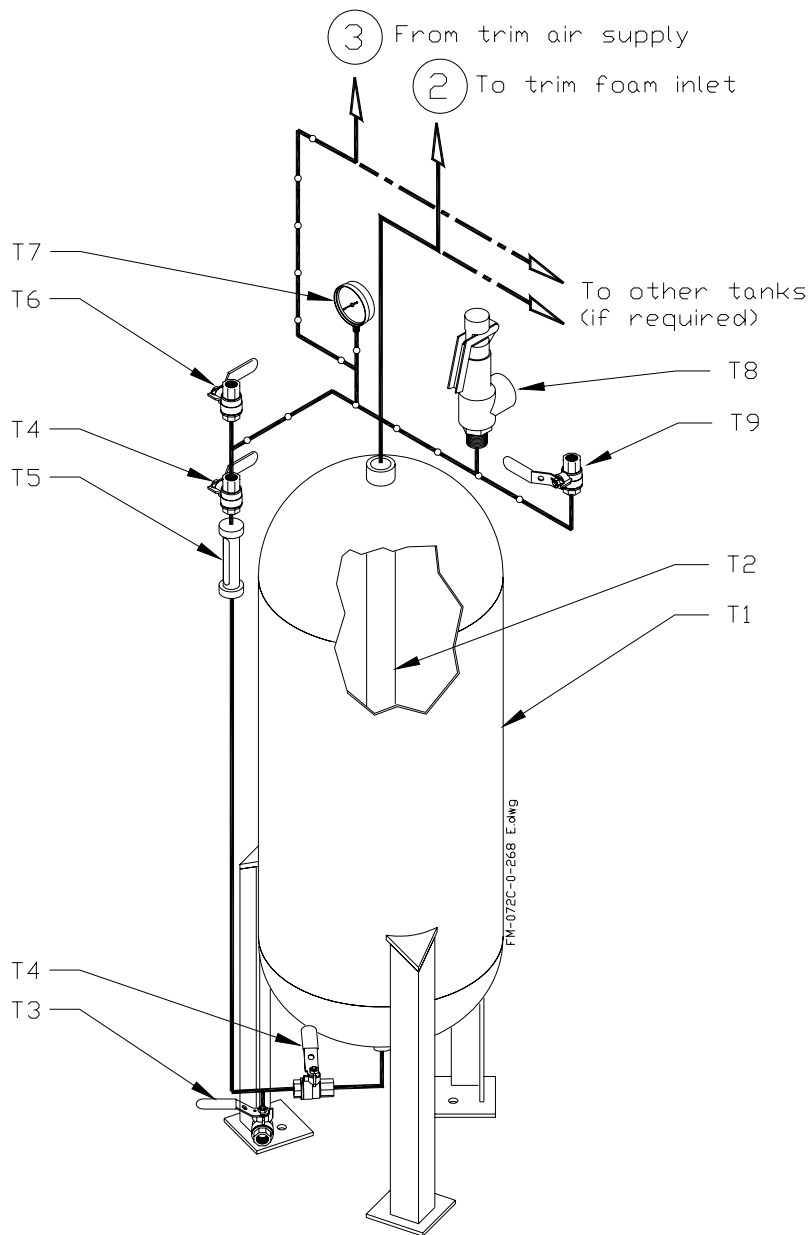

**Foam storage tank components:**

- |                                      |                           |
|--------------------------------------|---------------------------|
| T1 Foam storage tank                 | T6 Foam refill vent valve |
| T2 Dip tube                          | T7 Pressure gauge         |
| T3 Storage tank drain valve          | T8 Pressure safety valve  |
| T4 Level sight gauge isolation valve | T9 Foam refill valve      |
| T5 Foam level sight gauge            |                           |

### **Cabinet for Self-Contained Unit**

#### **(With Control Panel)**

The ICAF unit cabinet is made of sturdy 14 gauge steel, measuring 36" x 20" x 71" (91,4 x 50,8 x 180,3 cm) or 46" x 24" x 71" (116,8 x 61 x 180,3 cm) depending on the configuration provided. Refer to Figure 1 for dimensions.

All surfaces are rust proof coated, inside and outside, with fire red, oven baked polyester powder on phosphate base. Cabinet is provided with individual access doors for the hydraulic and electrical sections and the emergency release with a neoprene gasket to avoid vibrations.

Electrical junction boxes are integrated with the cabinet for connection of detection system, auxiliary contacts and signaling devices. Knockouts can be drilled by the installing contractor on-site but have to meet the restrictions indicated on Figure 2.

Gauges to indicate air, water supply pressure and priming water pressure are all visible through clear Lexan windows.

**IMPORTANT!** ICAF units are NOT designed to be installed where they will be subjected to outdoors and/or freezing conditions. Refer to ENVIRONMENTAL DATA for additional details. Subjecting the unit to conditions outside these limitations might hamper the normal operation of the system.

Cabinet doors are provided with hinges that can easily be disassembled on site to remove the door assemblies for servicing. The cabinet assembly is pre-assembled, pre-wired, and factory tested under ISO-9001 conditions.

**Note:** The mechanical section of the ICAF and the electrical section are provided in two separate enclosures, stacked one on top of the other.



# ICAF - Integrated Compressed Air Foam System

## System Characteristics Section

Figure 1 – Dimensions:

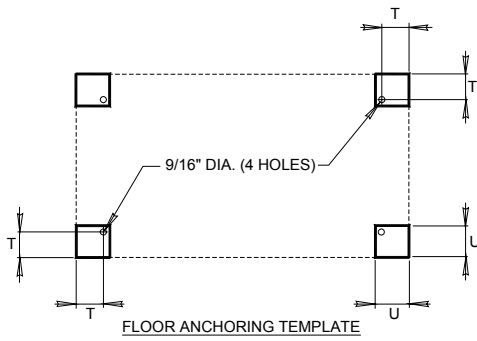
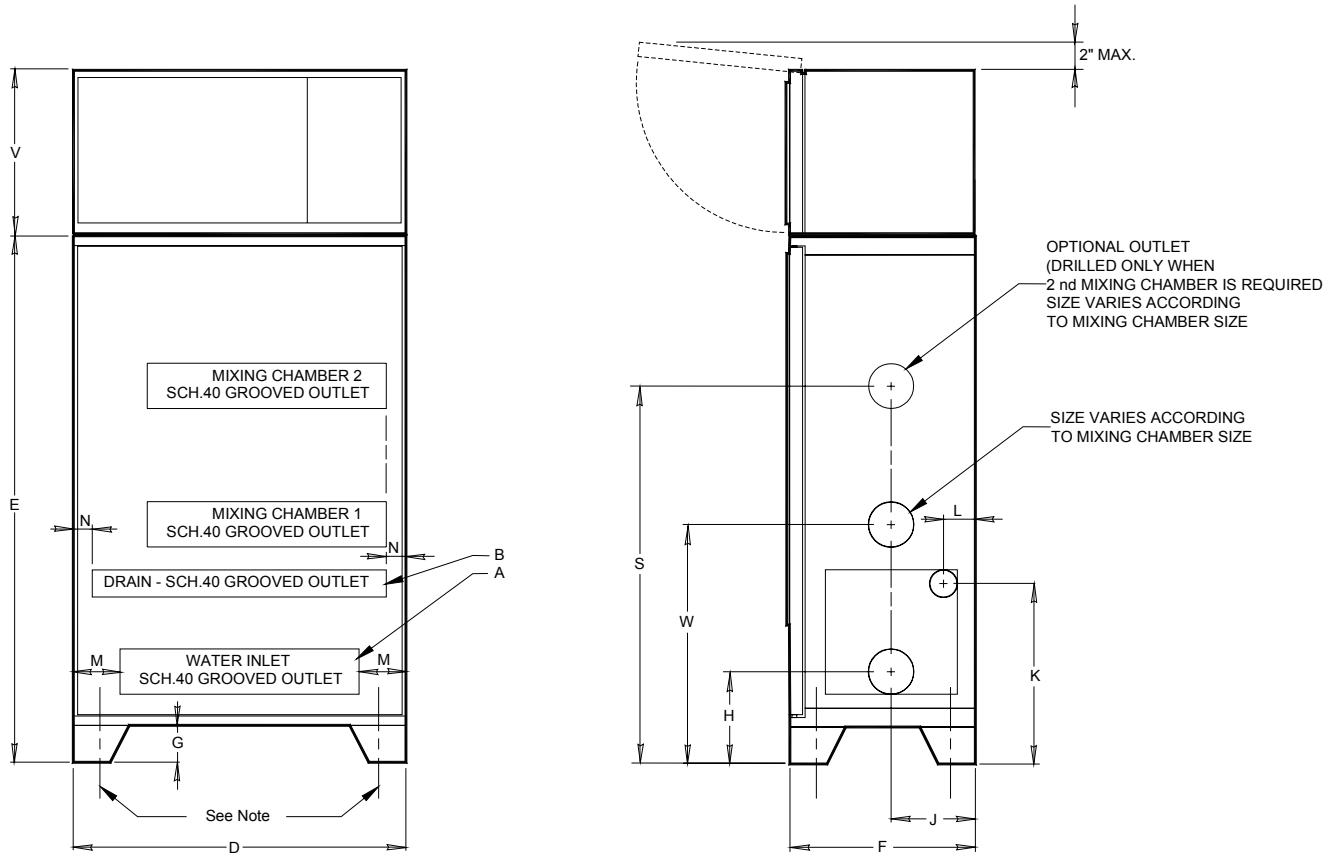

Note: Access holes provided on enclosure bottom plate to access anchoring holes.

A = WATER INLET DIAMETER  
B = DRAIN PIPE DIAMETER

FM-08GC-0-1C.dwg

System Size	A	B	D	E	F	G	H	J	K	L	M	N	S	T	U	V	W
3/4"	2"	2"	36"	57"	20"	4"	8 7/8"	9"	18 1/2"	3 1/2"	6"	2"	49 1/2"	2 3/4"	4"	14"	39 1/4"
1 1/2"	2"	2"	36"	57"	20"	4"	8 7/8"	9"	18 1/2"	3 1/2"	6"	2"	49 1/2"	2 3/4"	4"	14"	39 1/4"
2"	2"	2"	36"	57"	20"	4"	8 7/8"	9"	18 1/2"	3 1/2"	6"	2"	49 1/2"	2 3/4"	4"	14"	39 1/4"
3"	4"	2"	36"	57"	20"	4"	9 7/8"	9"	18 1/2"	3 1/2"	6"	2"	49 1/2"	2 3/4"	4"	14"	39 1/4"



## System Characteristics Section

### Drilling Guide:

When drilling in the cabinet to install wiring conduits or pipes, use only the shaded area shown below. Always avoid drilling into internal components.

**Figure 2 – Drilling detail:**

**IMPORTANT !** Drill holes in the two shaded areas only to avoid internal components and about 1/2" from cabinet rear edge as shown.

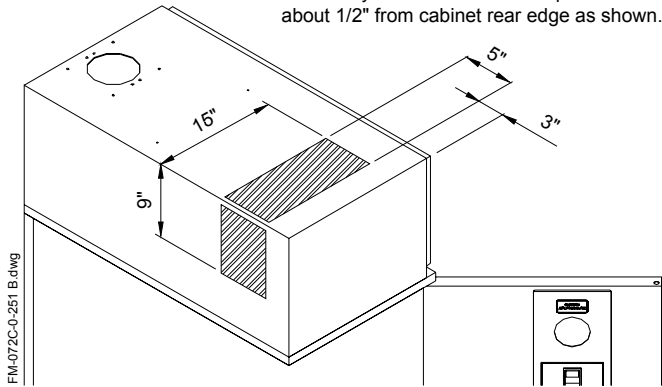

**Figure 3 – Wiring routing:**

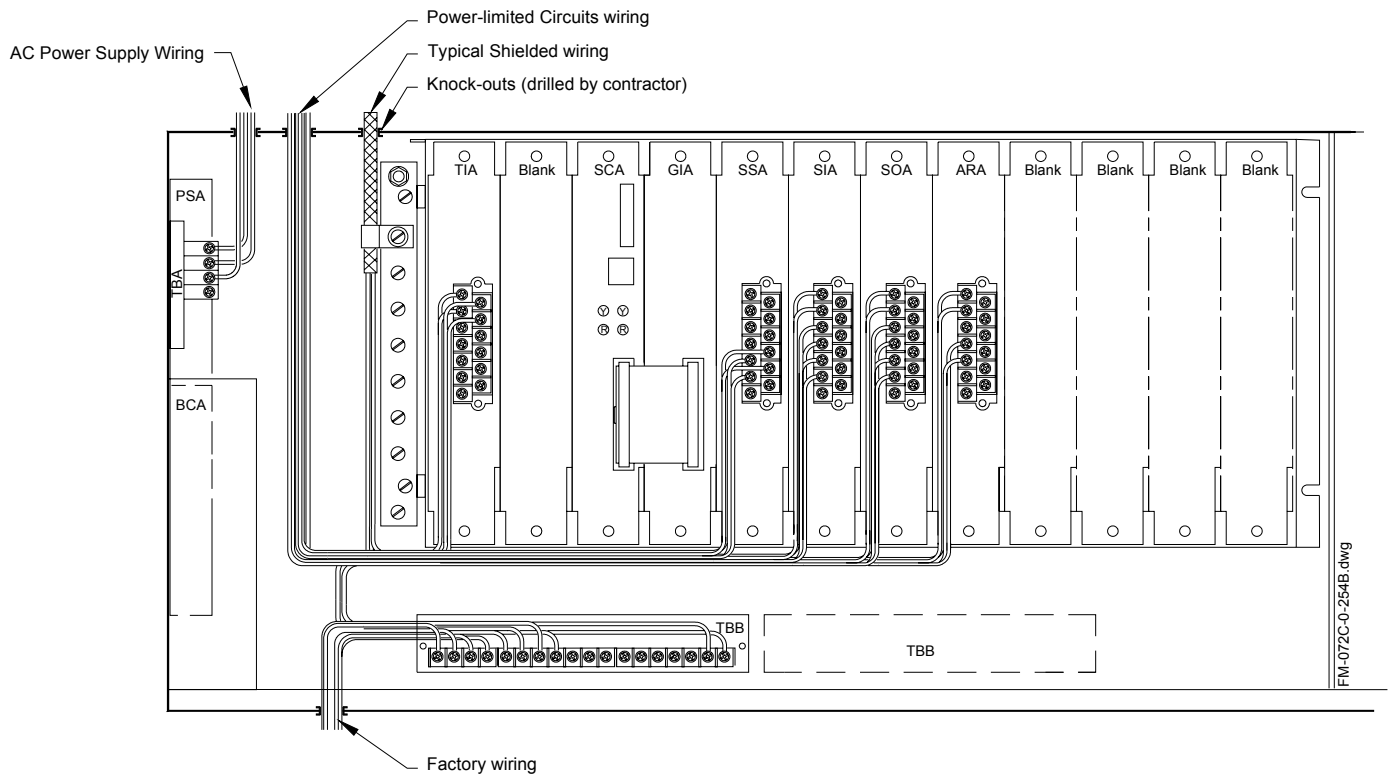

### Wiring Routing:

Wiring shown in Figure 3 below indicates typical Wiring Routing for Power Limited Circuits.

Refer to FIELD WIRING DIAGRAM and drilling guide above for details.